

MIATI TOOLS

Milling Insert And
Turning Insert Tools

F 铝用刀片 Aluminum Insert



F铝用刀片 Aluminum Insert

MIATI TOOLS

Milling Insert And
Turning Insert Tools

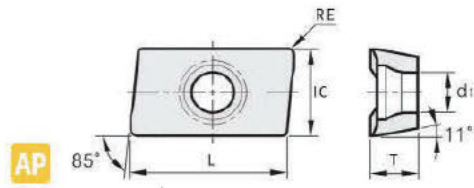

产品 Inserts Shape	型号 Type	尺寸 Dimensions(mm)			牌号 Grade
		L	T	RE	JTK101
	APKT1003	10.39	3.53	0.80	
	APKT1135-G2	11.45	3.52	0.70	
	APKT1604-MA	15.30	4.76	0.80	
	APKT1604-G2	15.30	4.76	0.80	
	APKT1604-MA3	15.30	4.76	0.80	

★主推牌号 Primary brand number ☆可选牌号 Optional brand ○按订单生产 Production to order

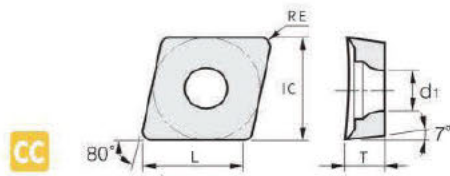

产品 Inserts Shape	型号 Type	尺寸 Dimensions(mm)					牌号 Grade
		L	IC	T	d1	RE	JTK101
	CCGT060202	6.40	6.35	2.38	2.80	0.20	
	CCGT060204	6.40	6.35	2.38	2.80	0.40	
	CCGT060208	6.40	6.35	2.38	2.80	0.80	
	CCGT09T302	9.70	9.52	3.97	4.40	0.20	
	CCGT09T304	9.70	9.52	3.97	4.40	0.40	
	CCGT09T308	9.70	9.52	3.97	4.40	0.80	
	CCGT120402	12.90	12.70	4.76	5.56	0.20	
	CCGT120404	12.90	12.70	4.76	5.56	0.40	
	CCGT120408	12.90	12.70	4.76	5.56	0.80	

★主推牌号 Primary brand number ☆可选牌号 Optional brand ○按订单生产 Production to order

F 铝用刀片 Aluminum Insert

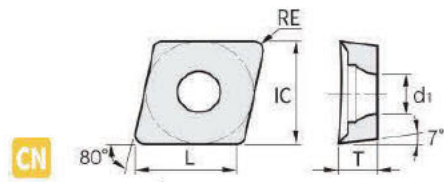

		尺寸 Dimensions(mm)					牌号 Grade
产品 Inserts Shape	型号 Type	L	IC	T	d1	RE	JTK101
	CNMG120402	12.90	12.70	4.76	5.16	0.2	
	CNMG120404	12.90	12.70	4.76	5.16	0.4	
	CNMG120408	12.90	12.70	4.76	5.16	0.8	
	CNMG120412	12.90	12.70	4.76	5.16	1.2	

★主推牌号 Primary brand number ☆可选牌号 Optional brand ○按订单生产 Production to order

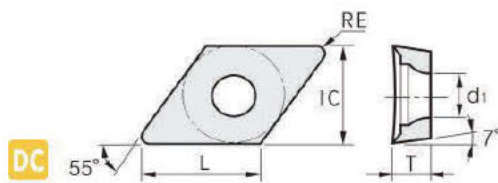

		尺寸 Dimensions(mm)					牌号 Grade
产品 Inserts Shape	型号 Type	L	IC	T	d1	RE	JTK101
	DCGT070202	7.80	6.35	2.38	2.80	0.20	
	DCGT070204	7.80	6.35	2.38	2.80	0.40	
	DCGT070208	7.80	6.35	2.38	2.80	0.80	
	DCGT11T302	11.60	9.52	3.97	4.40	0.20	
	DCGT11T304	11.60	9.52	3.97	4.40	0.40	
	DCGT11T308	11.60	9.52	3.97	4.40	0.80	

★主推牌号 Primary brand number ☆可选牌号 Optional brand ○按订单生产 Production to order

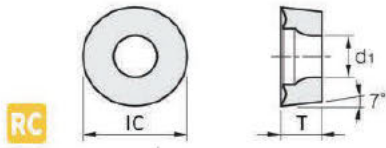

产品 Inserts Shape	型号 Type	尺寸 Dimensions(mm)			牌号 Grade
		IC	T	d1	JTK101
	RCGT0702	7.00	2.38	2.8	
	RCGT0802	8.00	2.38	3.4	
	RCGT1003	10.00	3.18	4.0	
	RCGT10T3	10.00	3.97	4.4	
	RCGT1204	12.00	4.76	4.4	

★主推牌号 Primary brand number ☆可选牌号 Optional brand ○按订单生产 Production to order

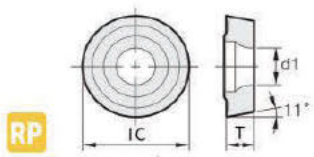

产品 Inserts Shape	型号 Type	尺寸 Dimensions(mm)			牌号 Grade
		IC	T	d1	JTK101
	RPGT0702	7.00	2.38	2.8	
	RPGT0802	8.00	2.38	3.4	
	RPGT1003	10.00	3.18	4.0	
	RPGT10T3MO	10.00	3.97	4.4	
	RPGT1204MO	12.00	4.76	4.4	

★主推牌号 Primary brand number ☆可选牌号 Optional brand ○按订单生产 Production to order

F铝用刀片 Aluminum Insert

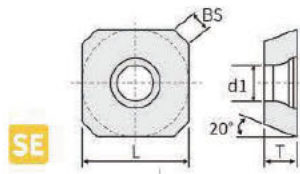

SE

尺寸 Dimensions(mm)							牌号 Grade
产品 Inserts Shape	型号 Type	L	IC	T	d1	BS	JTK101
	SEHT1204-AFFTN	12.7	12.7	4.76	5.5	3	

★主推牌号Primary brand number ☆可选牌号Optional brand ○按订单生产Production to order

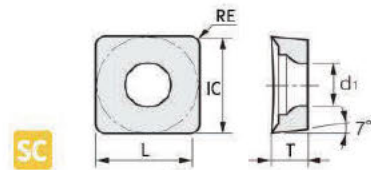

SC

尺寸 Dimensions(mm)							牌号 Grade
产品 Inserts Shape	型号 Type	L	IC	T	d1	RE	JTK101
	SCGT09T302	9.525	9.525	3.97	4.4	0.2	
	SCGT09T304	8.525	9.525	3.97	4.4	0.4	
	SCGT09T308	9.525	9.525	3.97	4.4	0.8	
	SCGT120402	12.7	9.525	4.76	5.56	0.2	
	SCGT120404	12.7	9.525	4.76	5.56	0.4	
	SCGT120408	12.7	9.525	4.76	5.56	0.8	
	SCGT120412	12.7	9.525	4.76	5.56	1.2	

★主推牌号Primary brand number ☆可选牌号Optional brand ○按订单生产Production to order

F铝用刀片 Aluminum Insert

MIATI TOOLS

Milling Insert And
Turning Insert Tools

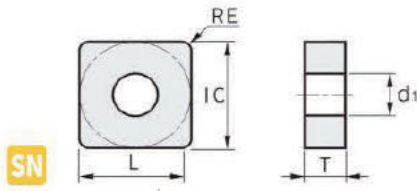

SN

		尺寸 Dimensions(mm)					牌号 Grade
产品 Inserts Shape	型号 Type	L	IC	T	d1	RE	JTK101
	SNMG120402	12.7	12.7	4.76	5.16	0.20	
	SNMG120404	12.7	12.7	4.76	5.16	0.40	
	SNMG120408	12.7	12.7	4.76	5.16	0.80	
	SNMG120412	12.7	12.7	4.76	5.16	1.20	

★主推牌号 Primary brand number ☆可选牌号 Optional brand □按订单生产 Production to order

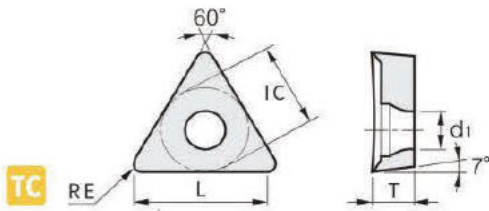

TC

		尺寸 Dimensions(mm)					牌号 Grade
产品 Inserts Shape	型号 Type	L	IC	T	d1	RE	JTK101
	TCGT090202	9.60	5.56	2.38	2.50	0.20	
	TCGT090204	9.60	5.56	2.38	2.50	0.40	
	TCGT110202	11.00	6.35	2.38	2.80	0.20	
	TCGT110204	11.00	6.35	2.38	2.80	0.40	
	TCGT110208	11.00	6.35	2.38	2.80	0.80	
	TCGT16T302	16.50	9.52	3.97	4.40	0.20	
	TCGT16T304	16.50	9.52	3.97	4.40	0.40	
	TCGT16T308	16.50	9.52	3.97	4.40	0.80	
	TCGT16T312	16.50	9.52	3.97	4.40	1.20	

★主推牌号 Primary brand number ☆可选牌号 Optional brand □按订单生产 Production to order

F 铝用刀片 Aluminum Insert

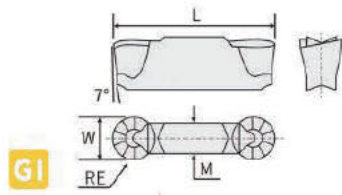

G1

		尺寸 Dimensions(mm)					牌号 Grade
产品 Inserts Shape	型号 Type	M	W	RE		JTK101	
	GIPA8.0-4.0	6.00	8.00	4.00			

★主推牌号 Primary brand number ☆可选牌号 Optional brand ○按订单生产 Production to order

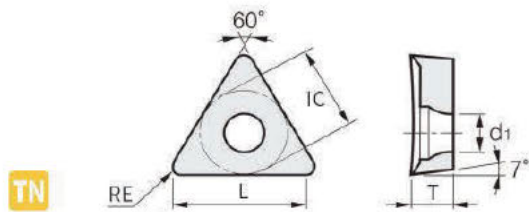

TN

		尺寸 Dimensions(mm)						牌号 Grade
产品 Inserts Shape	型号 Type	L	IC	T	d1	RE	JTK101	
	TNMG160402	16.50	9.525	4.76	3.81	0.20		
	TNMG160404	16.50	9.525	4.76	3.81	0.40		
	TNMG160408	16.50	9.525	4.76	3.81	0.80		
	TNMG160412	16.50	9.525	4.76	3.81	1.20		
	TNMG220404	22	12.7	4.76	5.16	0.40		
	TNMG220408	22	12.7	4.76	5.16	0.80		
	TNMG220412	22	12.7	4.76	5.16	1.20		

★主推牌号 Primary brand number ☆可选牌号 Optional brand ○按订单生产 Production to order

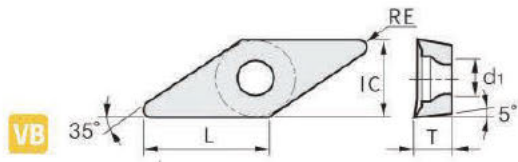

尺寸 Dimensions(mm)							牌号 Grade
产品 Inserts Shape	型号 Type	L	IC	T	d1	RE	JTK101
	VBGT110302	11.00	6.35	3.18	2.80	0.20	
	VBGT110304	11.00	6.35	3.18	2.80	0.40	
	VBGT110308	11.00	6.35	3.18	2.80	0.80	
	VBGT160402	16.50	9.52	4.76	4.40	0.20	
	VBGT160412	16.50	9.52	4.76	4.40	1.20	

★主推牌号 Primary brand number ☆可选牌号 Optional brand ○按订单生产 Production to order

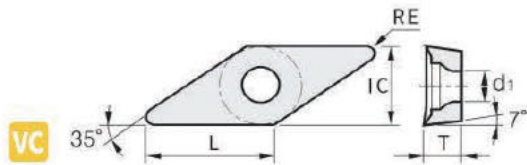

尺寸 Dimensions(mm)							牌号 Grade
产品 Inserts Shape	型号 Type	L	IC	T	d1	RE	JTK101
	VCGT110302	11.00	6.35	3.18	2.80	0.20	
	VCGT110304	11.00	6.35	3.18	2.80	0.40	
	VCGT110308	11.00	6.35	3.18	2.80	0.80	
	VCGT160402	16.50	9.52	4.76	4.40	0.20	
	VCGT160404	16.50	9.52	4.76	4.40	0.40	
	VCGT160408	16.50	9.52	4.76	4.40	0.80	
	VCGT160412	16.50	9.52	4.76	4.40	1.20	
	VCGT220530LX	22.00	12.70	5.56	5.50	3.00	
	VCGT220530AK	22.00	12.70	5.56	5.50	3.00	

★主推牌号 Primary brand number ☆可选牌号 Optional brand ○按订单生产 Production to order

F 铝用刀片 Aluminum Insert

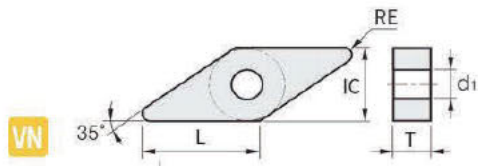

尺寸 Dimensions(mm)							牌号 Grade
产品 Inserts Shape	型号 Type	L	IC	T	d1	RE	JTK101
	VNMG160402	16.60	9.52	4.76	3.81	0.20	
	VNMG160404	16.60	9.52	4.76	3.81	0.40	
	VNMG160408	16.60	9.52	4.76	3.81	0.80	
	VNMG160412	16.60	9.52	4.76	3.81	1.20	

★主推牌号 Primary brand number ☆可选牌号 Optional brand ○按订单生产 Production to order

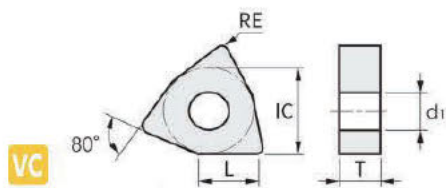

尺寸 Dimensions(mm)							牌号 Grade
产品 Inserts Shape	型号 Type	L	IC	T	d1	RE	JTK101
	WNMG080402	8.70	12.70	4.76	5.16	0.2	
	WNMG080404	8.70	12.70	4.76	5.16	0.4	
	WNMG080408	8.70	12.70	4.76	5.16	0.8	

★主推牌号 Primary brand number ☆可选牌号 Optional brand ○按订单生产 Production to order



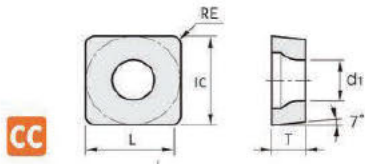

产品 Inserts Shape	型号 Type	尺寸 Dimensions(mm)					可选牌号 Grade For Choice			
		L	IC	T	d1	RE	JT3000	JT6000	TP3000	TP6000
	CCMT060204-MT	6.40	6.35	2.38	2.80	0.40	★			
	CCMT09T304-MT	9.70	9.52	3.97	4.40	0.40	★			
	CCMT09T308-MT	9.70	9.52	3.97	4.40	0.80	★			
	CCMT120404-MT	12.90	12.70	4.76	5.16	0.40	★			

★主推牌号 Primary brand number ☆可选牌号 Optional brand ○按订单生产 Production to order

产品 Inserts Shape	型号 Type	尺寸 Dimensions(mm)					可选牌号 Grade For Choice			
		L	IC	T	d1	RE	JT3000	JT6000	TP3000	TP6000
	CCMT060204-FG	6.40	6.35	2.38	2.80	0.40	★			
	CCMT09T304-FG	9.70	9.52	3.97	4.40	0.40	★			

★主推牌号 Primary brand number ☆可选牌号 Optional brand ○按订单生产 Production to order

G金属陶瓷刀片 Cermet Insert

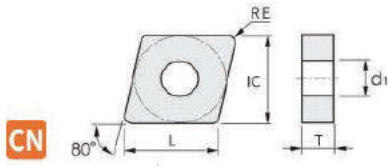

产品 Inserts Shape	型号 Type	尺寸 Dimensions(mm)					可选牌号 GradeForChoice			
		L	IC	T	d1	RE	JT3000	JT6000	TP3000	TP6000
	CNMG120404-MT	12.90	12.70	4.76	5.16	0.40	★			
	CNMG120408-MT	12.90	12.70	4.76	5.16	0.80	★			

★主推牌号Primary brand number ☆可选牌号Optional brand ○按订单生产Production to order

产品 Inserts Shape	型号 Type	尺寸 Dimensions(mm)					可选牌号 GradeForChoice			
		L	IC	T	d1	RE	JT3000	JT6000	TP3000	TP6000
	CNMG120404-FG	12.90	12.70	4.76	5.16	0.40	★			
	CNMG120408-FG	12.90	12.70	4.76	5.16	0.80	★			

★主推牌号Primary brand number ☆可选牌号Optional brand ○按订单生产Production to order

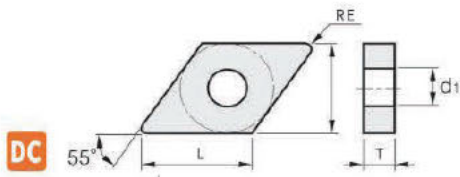

产品 Inserts Shape	型号 Type	尺寸 Dimensions(mm)					可选牌号 GradeFor Choice			
		L	IC	T	d1	RE	JT3000	JT6000	TP3000	TP6000
	DCMT070204-FG	7.80	6.35	2.38	2.80	0.40	★			
	DCMT11T304-FG	11.6	9.52	3.97	4.40	0.40	★			
	DCMT11T308-FG	11.6	9.52	3.97	4.40	0.80	★			

★主推牌号Primary brand number ☆可选牌号Optional brand ○按订单生产Production to order

产品 Inserts Shape	型号 Type	尺寸 Dimensions(mm)					可选牌号 GradeFor Choice			
		L	IC	T	d1	RE	JT3000	JT6000	TP3000	TP6000
	DCMT11T304-MT	11.6	9.52	3.97	4.40	0.40	★			
	DCMT11T308-MT	11.6	9.52	3.97	4.40	0.80	★			

★主推牌号Primary brand number ☆可选牌号Optional brand ○按订单生产Production to order

G 金属陶瓷刀片 Cermet Insert

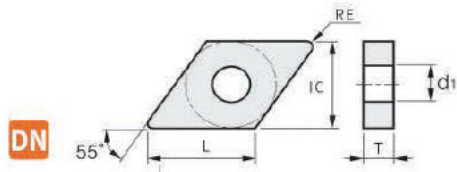

产品 Inserts Shape	型号 Type	尺寸 Dimensions(mm)					可选牌号 Grade For Choice			
		L	IC	T	d1	RE	JT3000	JT6000	TP3000	TP6000
	DNMG150404-MT	15.50	12.70	4.76	5.16	0.40	★			
	DNMG150408-MT	15.50	12.70	4.76	5.16	0.80	★			

★主推牌号 Primary brand number ☆可选牌号 Optional brand ○按订单生产 Production to order

产品 Inserts Shape	型号 Type	尺寸 Dimensions(mm)					可选牌号 Grade For Choice			
		L	IC	T	d1	RE	JT3000	JT6000	TP3000	TP6000
	DNMG150404R-VF	15.50	12.70	4.76	5.16	0.40	★			
	DNMG150408R-VF	15.50	12.70	4.76	5.16	0.80	★			

★主推牌号 Primary brand number ☆可选牌号 Optional brand ○按订单生产 Production to order

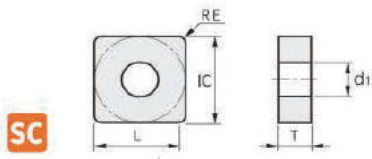

SC

尺寸 Dimensions(mm)

可选牌号 GradeFor Choice

产品 Inserts Shape	型号 Type	L	IC	T	d1	RE	可选牌号 GradeFor Choice			
							JT3000	JT6000	TP3000	TP6000
	SCMT09T304-MT	9.525	9.525	3.97	4.4	0.4	★			

★主推牌号Primary brand number ☆可选牌号Optional brand ○按订单生产Production to order

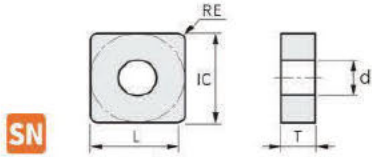

SN

尺寸 Dimensions(mm)

可选牌号 GradeFor Choice

产品 Inserts Shape	型号 Type	L	IC	T	d1	RE	可选牌号 GradeFor Choice			
							JT3000	JT6000	TP3000	TP6000
	SNMG120404-MT	12.7	12.7	4.76	5.16	0.4	★			
	SNMG120408-MT	12.7	12.7	4.76	5.16	0.8	★			

★主推牌号Primary brand number ☆可选牌号Optional brand ○按订单生产Production to order

G 金属陶瓷刀片 Cermet Insert

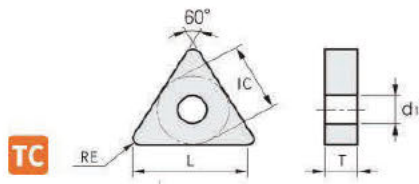

尺寸 Dimensions(mm)							可选牌号 GradeForChoice			
产品 Inserts Shape	型号 Type	L	IC	T	d1	RE	JT3000	JT6000	TP3000	TP6000
	TCMT090204-MT	9.60	5.56	2.38	2.50	0.40	★			
	TCMT110204-MT	11.00	6.35	2.38	2.80	0.40	★			
	TCMT16T304-MT	16.50	9.52	3.97	4.40	0.40	★			
	TCMT16T308-MT	16.50	9.52	3.97	4.40	0.80	★			

★主推牌号Primary brand number ☆可选牌号Optional brand ○按订单生产Production to order

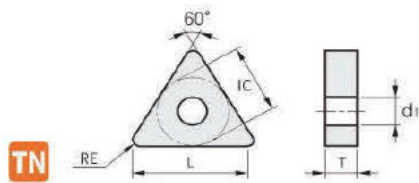

尺寸 Dimensions(mm)							可选牌号 GradeForChoice			
产品 Inserts Shape	型号 Type	L	IC	T	d1	RE	JT3000	JT6000	TP3000	TP6000
	TNMG160404-MT	16.50	9.52	4.76	3.81	0.40	★			
	TNMG160408-MT	16.50	9.52	4.76	3.81	0.80	★			

★主推牌号Primary brand number ☆可选牌号Optional brand ○按订单生产Production to order

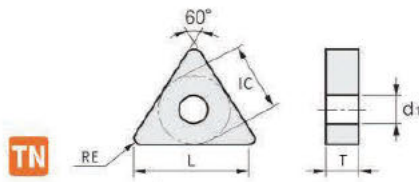

产品 Inserts Shape	型号 Type	尺寸 Dimensions(mm)					可选牌号 GradeFor Choice			
		L	IC	T	d1	RE	JT3000	JT6000	TP3000	TP6000
	TNMG160404-FG	16.50	9.52	4.76	3.81	0.40	★			
	TNMG160408-FG	16.50	9.52	4.76	3.81	0.80	★			

★主推牌号 Primary brand number ☆可选牌号 Optional brand ○按订单生产 Production to order

产品 Inserts Shape	型号 Type	尺寸 Dimensions(mm)					可选牌号 GradeFor Choice			
		L	IC	T	d1	RE	JT3000	JT6000	TP3000	TP6000
	TNMG160404R-VF	16.50	9.52	4.76	3.81	0.40	★			
	TNMG160408R-VF	16.50	9.52	4.76	3.81	0.80	★			
	TNMG160404L-VF	16.50	9.52	4.76	3.81	0.40	★			
	TNMG160408L-VF	16.50	9.52	4.76	3.81	0.80	★			

★主推牌号 Primary brand number ☆可选牌号 Optional brand ○按订单生产 Production to order

G 金属陶瓷刀片 Cermet Insert

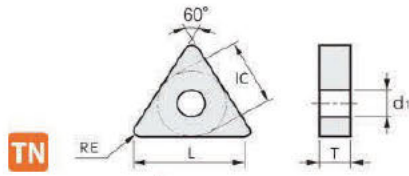

产品 Inserts Shape	型号 Type	尺寸 Dimensions(mm)					可选牌号 GradeForChoice			
		L	IC	T	d1	RE	JT3000	JT6000	TP3000	TP6000
	TNMG160404R-FS	16.50	9.52	4.76	3.81	0.40	★			
	TNMG160408R-FS	16.50	9.52	4.76	3.81	0.80	★			
	TNMG160404L-FS	16.50	9.52	4.76	3.81	0.40	★			
	TNMG160408L-FS	16.50	9.52	4.76	3.81	0.80	★			

★主推牌号Primary brand number ☆可选牌号Optional brand ○按订单生产Production to order

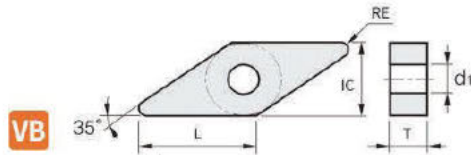

产品 Inserts Shape	型号 Type	尺寸 Dimensions(mm)					可选牌号 GradeForChoice			
		L	IC	T	d1	RE	JT3000	JT6000	TP3000	TP6000
	VBMT160404-FG	16.50	9.52	4.76	4.40	0.40	★			

★主推牌号Primary brand number ☆可选牌号Optional brand ○按订单生产Production to order

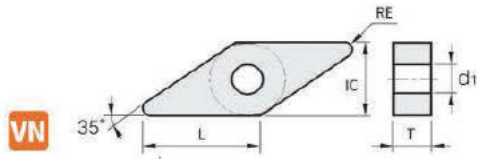

尺寸 Dimensions(mm)

可选牌号 GradeForChoice

产品 Inserts Shape	型号 Type	L	IC	T	d1	RE	JT3000	JT6000	TP3000	TP6000
	VNMG160404-MT	16.60	9.52	4.76	3.81	0.40	★			
	VNMG160408-MT	16.60	9.52	4.76	3.81	0.80	★			

★主推牌号 Primary brand number ☆可选牌号 Optional brand ○按订单生产 Production to order

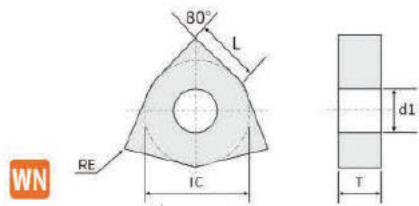

尺寸 Dimensions(mm)

可选牌号 GradeForChoice

产品 Inserts Shape	型号 Type	L	IC	T	d1	RE	JT3000	JT6000	TP3000	TP6000
	WNMG080404-MT	8.70	12.70	4.76	5.16	0.40	★			
	WNMG080408-MT	8.70	12.70	4.76	5.16	0.80	★			

★主推牌号 Primary brand number ☆可选牌号 Optional brand ○按订单生产 Production to order

G 金属陶瓷刀片 Cermet Insert

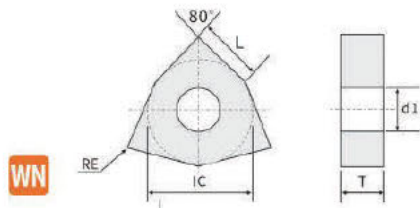

产品 Inserts Shape	型号 Type	尺寸 Dimensions(mm)					可选牌号 Grade For Choice			
		L	IC	T	d1	RE	JT3000	JT6000	TP3000	TP6000
	WNMG080404-FG	8.70	12.70	4.76	5.16	0.40	★			
	WNMG080408-FG	8.70	12.70	4.76	5.16	0.80	★			

★主推牌号 Primary brand number ☆可选牌号 Optional brand ○按订单生产 Production to order

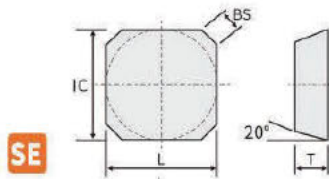

产品 Inserts Shape	型号 Type	尺寸 Dimensions(mm)					可选牌号 Grade For Choice			
		L	IC	T	BS	JT3000	JT6000	TP3000	TP6000	
	SEKN1203AFTN	12.70	12.70	3.18	1.80	★				
	SEKN1504AFTN	15.88	15.88	4.76	1.60	★				

★主推牌号 Primary brand number ☆可选牌号 Optional brand ○按订单生产 Production to order

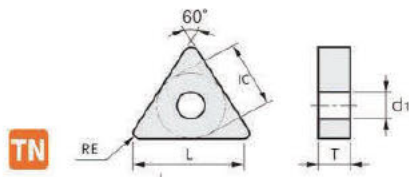

		尺寸 Dimensions(mm)					可选牌号 GradeFor Choice			
产品 Inserts Shape	型号 Type	L	IC	T	d1	RE	JT3000	JT6000	TP3000	TP6000
	TNGG160402R-C	16.50	9.52	4.76	3.81	0.20	★			
	TNGG160404R-C	16.50	9.52	4.76	3.81	0.40	★			
	TNGG160408R-C	16.50	9.52	4.76	3.81	0.80	★			
	TNGG160402L-C	16.50	9.52	4.76	3.81	0.20	★			
	TNGG160404L-C	16.50	9.52	4.76	3.81	0.40	★			
	TNGG160408L-C	16.50	9.52	4.76	3.81	0.80	★			

★主推牌号Primary brand number ☆可选牌号Optional brand ○按订单生产Production to order

		尺寸 Dimensions(mm)					可选牌号 GradeFor Choice			
产品 Inserts Shape	型号 Type	L	IC	T	d1	RE	JT3000	JT6000	TP3000	TP6000
	TNGG160402R-S	16.50	9.52	4.76	3.81	0.20	★			
	TNGG160404R-S	16.50	9.52	4.76	3.81	0.40	★			
	TNGG160402L-S	16.50	9.52	4.76	3.81	0.20	★			
	TNGG160404L-S	16.50	9.52	4.76	3.81	0.40	★			

★主推牌号Primary brand number ☆可选牌号Optional brand ○按订单生产Production to order

C槽刀片 Grooving Insert



C槽刀片 Grooving Insert

MIATI TOOLS

Milling Insert And
Turning Insert Tools

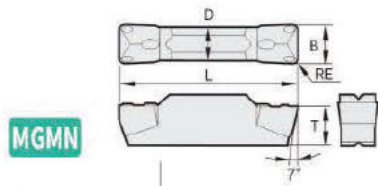

尺寸 Dimensions(mm)

可选牌号 Grade For Choice

产品 Inserts Shape	型号 Type	L	T	B	D	RE	可选牌号 Grade For Choice				
							TC720	TC721	TP621	TP622	TP623
	MGMN150-G	16.0	3.50	1.50	1.20	0.15	○				★
	MGMN200-G	16.0	3.50	2.00	1.60	0.20	○				★

★主推牌号 Primary brand number ☆可选牌号 Optional brand ○按订单生产 Production to order

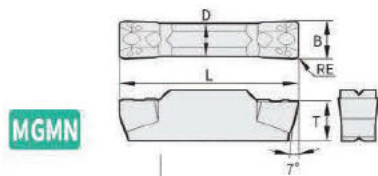

尺寸 Dimensions(mm)

可选牌号 Grade For Choice

产品 Inserts Shape	型号 Type	L	T	B	D	RE	可选牌号 Grade For Choice				
							TC720	TC721	TP621	TP622	TP623
	MGMN250-M	18.5	3.85	2.50	2.00	0.20	○				★
	MGMN300-M	21.0	4.80	3.00	2.35	0.40	○				★
	MGMN400-M	21.0	4.80	4.00	3.30	0.40	○				★
	MGMN500-M	26.0	5.80	5.00	4.10	0.80	○				★
	MGMN600-M	26.0	5.80	6.00	5.00	0.80	○				★

★主推牌号 Primary brand number ☆可选牌号 Optional brand ○按订单生产 Production to order

C槽刀片 Grooving Insert

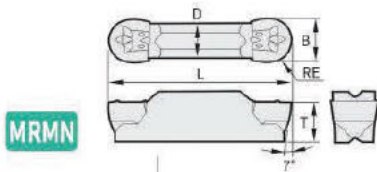

MRMN

尺寸 Dimensions(mm)

可选牌号 Grade For Choice

产品 Inserts Shape	型号 Type	L	T	B	D	RE	TC720	TC721	TP621	TP622	TP623	TP624
	MRMN200-M	16.0	3.50	2.00	1.50	1.00	○				★	
	MRMN300-M	21.0	4.80	3.00	2.35	1.50	○				★	
	MRMN400-M	21.0	4.80	4.00	3.30	2.00	○				★	
	MRMN500-M	26.0	5.80	5.00	4.10	2.50	○				★	

★主推牌号 Primary brand number ☆可选牌号 Optional brand ○按订单生产 Production to order

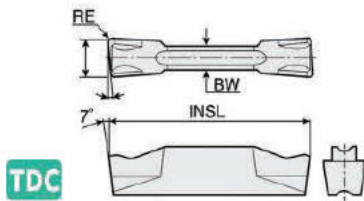

TDC

尺寸 Dimensions(mm)

可选牌号 Grade For Choice

产品 Inserts Shape	型号 Type	L	BW	RE	TC720	TC721	TP621	TP622	TP623	TP624
	TDC2	19	1.7	0.20			○	★		
	TDC3	19	2.4	0.20			○	★		
	TDC4	19	3.0	0.30			○	★		

★主推牌号 Primary brand number ☆可选牌号 Optional brand ○按订单生产 Production to order

C槽刀片 Grooving Insert

MIATI TOOLS

Milling Insert And
Turning Insert Tools

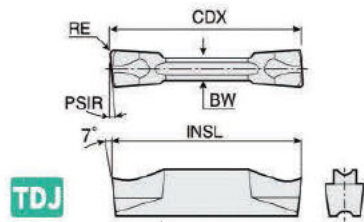

TDJ

尺寸 Dimensions(mm)

可选牌号 Grade For Choice

产品 Inserts Shape	型号 Type	L	BW	RE	可选牌号 Grade For Choice					
					TC720	TC721	TP621	TP622	TP623	TP624
	TDJ2	19	1.7	0.20			○	★		
	TDJ3	19	2.4	0.20			○	★		
	TDJ4	19	3.0	0.40			○	★		

★主推牌号 Primary brand number ☆可选牌号 Optional brand ○按订单生产 Production to order

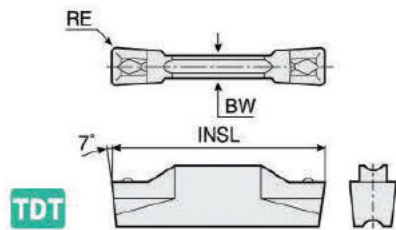

TDT

尺寸 Dimensions(mm)

可选牌号 Grade For Choice

产品 Inserts Shape	型号 Type	L	BW	RE	可选牌号 Grade For Choice					
					TC720	TC721	TP621	TP622	TP623	TP624
	TDT3	20.0	2.2	0.4			○	★		
	TDT4	20.0	3.0	0.4			○	★		

★主推牌号 Primary brand number ☆可选牌号 Optional brand ○按订单生产 Production to order

C槽刀片 Grooving Insert

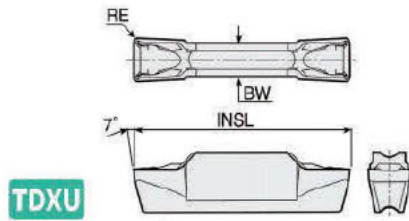

TDXU

尺寸 Dimensions(mm)

可选牌号 Grade For Choice

产品 Inserts Shape	型号 Type	L	BW	RE	可选牌号 Grade For Choice					
					TC720	TC721	TP621	TP622	TP623	TP624
	TDXU2	20.0	2.0	0.2			○	★		
	TDXU3	20.0	3.0	0.3			○	★		
	TDXU4	20.0	4.0	0.4			○	★		

★主推牌号 Primary brand number ☆可选牌号 Optional brand ○按订单生产 Production to order

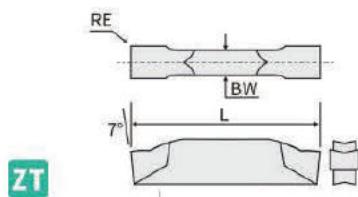

ZT

尺寸 Dimensions(mm)

可选牌号 Grade For Choice

产品 Inserts Shape	型号 Type	L	BW	RE	可选牌号 Grade For Choice					
					TC720	TC721	TP621	TP622	TP623	TP624
	ZTED02503-MG	17.00	2.50	0.30					○	
	ZTFD0303-MG	17.00	3.00	0.30					○	
	ZTGD0404-MG	22.00	4.00	0.40					○	
	ZTHD0504-MG	22.00	5.00	0.40					○	
	ZTKD0608-MG	22.00	6.00	0.80					○	

★主推牌号 Primary brand number ☆可选牌号 Optional brand ○按订单生产 Production to order

B 铣削刀片 Milling Insert



刀片形状/代号 The blade shape/code			公制 metric system								
代号 Code	有无孔 No/with hole	有无断屑槽 Presence of chip breaker groove	刀片剖面 Blade profile	代号 Code	有无孔 No/with hole	有无断屑槽 Presence of chip breaker groove	刀片剖面 Blade profile				
	A		B	有 have	无 not have		>65°	N	无 not have	无 not have	
	D		E	有 have	单面 single face		>65°	H	有 have	单面 single face	
	K		L	有 have	无 not have		>65°	C	有 have	无 not have	
	M		O	有 have	无 not have		>65°	J	有 have	双面 two-sided	
	P		R	有 have	无 not have		≤65°	W	有 have	无 not have	
	S		T	有 have	单面 single face		≤65°	T	有 have	单面 single face	
	V		W	有 have	无 not have		≤65°	Q	有 have	无 not have	
	Z	其他 Other	其他 Other	有 have	双面 two-sided		≤65°	U	有 have	双面 two-sided	
											特殊 special

形状代号 Shape code

断屑槽及夹固形式 Chip breaker groove, and solid forms



主切削刃后角 After the main cutting edge Angle

代号 Code	后角 clearance angle	代号 Code	后角 clearance angle
A		B	
C		D	
E		F	
G		N	
P		O	其他的后角 Other rear corner

公差 Tolerance

代号 Code	刀片厚度m/公差(mm) Blade thickness/tolerance (mm)	内切圆r1/公差(mm) In-circle r1/tolerance (mm)	厚度公差(mm) Thickness tolerance (mm)	(参考M级精度详细情况 (按形状、大小分) Refer to the class accuracy of detail according to the shape and size)								
				● 刀片厚度公差 (mm) / Blade thickness tolerance (mm)								
A	±0.005	±0.025	±0.025	内接圆 incircle	正三角形 regular triangle	正方形 square	80°菱形 80° rhombus	55°菱形 55° rhombus	35°菱形 35° rhombus	圆形 roundness		
F	±0.005	±0.013	±0.025	6.35	±0.08	±0.08	±0.08	±0.11	±0.16	---		
C	±0.013	±0.025	±0.025	9.525	±0.08	±0.08	±0.08	±0.11	±0.16	---		
H	±0.013	±0.013	±0.025	12.7	±0.13	±0.13	±0.13	±0.15	---	---		
E	±0.025	±0.025	±0.025	15.875	±0.15	±0.15	±0.15	±0.18	---	---		
G	±0.025	±0.025	±0.13	19.05	±0.15	±0.15	±0.15	±0.18	---	---		
J	±0.005	±0.05-±0.13	±0.025	25.4	---	±0.18	---	---	---	---		
				● 内切圆r1 C/公差 (mm) / In-circle r1 C/Tolerance (mm)								
K	±0.013	±0.05-±0.13	±0.025	内接圆 incircle	正三角形 regular triangle	正方形 square	80°菱形 80° rhombus	55°菱形 55° rhombus	35°菱形 35° rhombus	圆形 roundness		
L	±0.025	±0.05-±0.13	±0.025	6.35	±0.05	±0.05	±0.05	±0.05	±0.05	---		
M	±0.08-±0.18	±0.05-±0.13	±0.13	9.525	±0.05	±0.05	±0.05	±0.05	±0.05	±0.05		
N	±0.08-±0.18	±0.05-±0.13	±0.025	12.7	±0.08	±0.08	±0.08	±0.08	---	±0.08		
U	±0.13-±0.38	±0.08-±0.25	±0.13	15.875	±0.10	±0.10	±0.10	±0.10	---	±0.10		
				19.05	±0.10	±0.10	±0.10	±0.10	---	±0.10		
				25.4	---	±0.13	---	---	---	±0.13		

铣削刀片命名规则 Miling Insert Naming Rule

内切圆直径 (mm) (inscribed circle diameter (mm))	刀片形状 The blade shape/code						
	C	D	R	S	T	V	W
3.97					06		
5.0			05				
5.56					09		
6.0			06				
6.35	06	07			11	11	
8.0			08				
9.525	09	11	09	09	16	16	06
10.0			10				
12.0			12				
12.7	12	15	12	12	22	22	08
15.875	16		15	15	27		
16.0		19	16				
19.05	19		19	19	33		
20.0			20				
25.0	25	25	25				
25.4			25	25			
31.75			31				
32			32				

代号 Code	刀片厚度 (mm) Blade thickness (mm)
00	0.79
T0	0.99
01	1.59
T1	1.98
02	2.38
T2	2.58
03	3.18
T3	3.97
04	4.76
T4	4.96
05	5.96
T5	5.95
06	6.35
T6	6.75
07	7.94
09	9.52
T9	9.72
11	11.11
12	12.70



切削刃长度 The length of the cutting edge 刀片厚度 Blade thickness

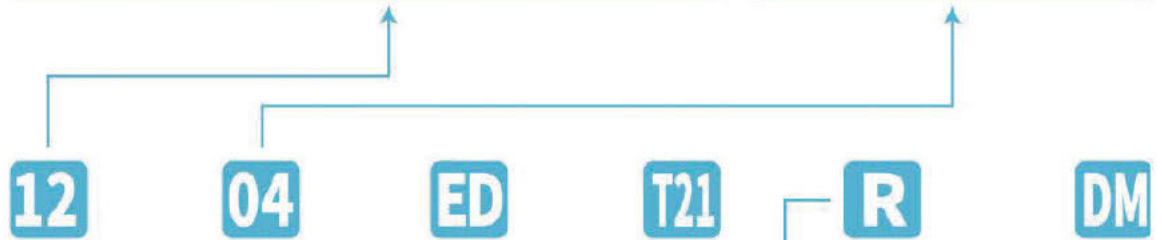

修光刃 B Wiper B

		α_n		α_n
A	45°	A	3°	
D	60°	B	3°	
E	75°	C	7°	
F	85°	D	15°	
P	90°	E	20°	
Z	其他 other	F	25°	
		G	30°	
		N	0°	
		P	11°	
		Z	其他 other	

切削刃倒棱 (mm) B Cutting edge chamfer (mm) B

Code	Diagram	Angle	Code	Diagram	Value
F		0-5°	K		0-10
E		1-10°	P		1-0.15
T		2-15°	W		2-0.20
S		3-20°			3-0.25
		4-25°			4-0.30
		5-30°			4-0.35
					5-0.35
					6-0.40
					7-0.45

断屑槽代号 The code chip breaker groove

R	
P	
W	
不标 Non-standard	

切削方向 B Cutting direction B

R	左
L	右
N	双向

B 铣削刀片 Milling Insert

MIATI TOOLS

Milling Insert And
Turning Insert Tools

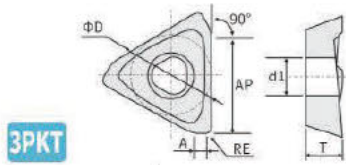

3PKT

产品 Inserts Shape	型号 Type	尺寸 Dimensions(mm)					可选牌号 Grade For Choice												
		ΦD	AP	T	A	RE	TC420	TC422	TC520	TC521	TC522	TC620	TC622	TP621	TP622	TP624	TP721	TP722	TP724
	3PKT060304R-M	5.3	4.7	2.8	1.0	0.4							○	★	☆				
	3PKT100408R-M	6.9	7.0	4.0	1.2	0.8							○	★	☆				
	3PKT150508R-M	10.7	11.0	5.0	1.8	0.8							○	★	☆				
	3PKT190608R-M	13.5	15.0	6.0	2.0	0.8							○	★	☆				

★主推牌号Primary brand number ☆可选牌号Optional brand ○按订单生产Production to order

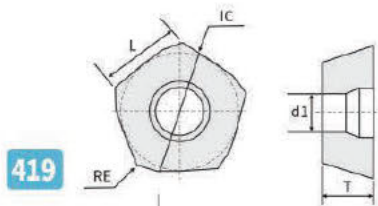

419

产品 Inserts Shape	型号 Type	尺寸 Dimensions(mm)					可选牌号 Grade For Choice												
		IC	L	T	d1	RE	TC420	TC422	TC520	TC521	TC522	TC620	TC622	TP621	TP622	TP624	TP721	TP722	TP724
	419R-1405M-PM	13.5	9	5.47	5.5	0.8							★	○	★	☆			

★主推牌号Primary brand number ☆可选牌号Optional brand ○按订单生产Production to order

B 铣削刀片 Milling Insert

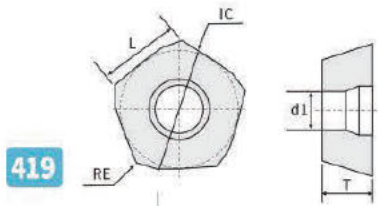

419

尺寸 Dimensions(mm)

可选牌号 Grade For Choice

产品 Inserts Shape	型号 Type	IC	L	T	d1	RE	可选牌号 Grade For Choice													
							TC420	TC422	TC520	TC521	TC522	TC620	TC622	TP621	TP622	TP624	TP721	TP722	TP724	
	419R-1405M-PH	13.5	9	5.47	5.5	0.8	★										☆			

★主推牌号 Primary brand number ☆可选牌号 Optional brand ○按订单生产 Production to order

产品 Inserts Shape	型号 Type	IC	L	T	d1	RE	可选牌号 Grade For Choice													
							TC420	TC422	TC520	TC521	TC522	TC620	TC622	TP621	TP622	TP624	TP721	TP722	TP724	
	419N-140530M-KH	13.5	9	5.47	5.5	3	★											☆		

★主推牌号 Primary brand number ☆可选牌号 Optional brand ○按订单生产 Production to order

B 铣削刀片 Milling Insert

419

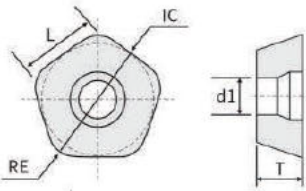

尺寸 Dimensions(mm)

可选牌号 Grade For Choice

产品 Inserts Shape	型号 Type	IC	L	T	d1	RE	TC420	TC422	TC520	TC521	TC522	TC620	TC622	TP621	TP622	TP624	TP721	TP722	TP724		
								419N-140530E-SM	13.5	9	5.47	5.5	3						★	□	
						3															

★主推牌号Primary brand number ☆可选牌号Optional brand □按订单生产Production to order

4NKT

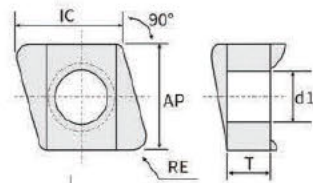

尺寸 Dimensions(mm)

可选牌号 Grade For Choice

产品 Inserts Shape	型号 Type	IC	AP	T	RE	TC420	TC422	TC520	TC521	TC522	TC620	TC622	TP621	TP622	TP624	TP721	TP722	TP724			
							4NKT060308R-M	6.6	6.0	4.67	0.8								□		★

★主推牌号Primary brand number ☆可选牌号Optional brand □按订单生产Production to order

B 铣削刀片 Milling Insert

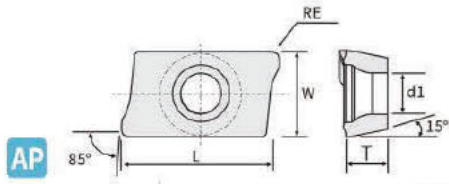

产品 Inserts Shape	型号 Type	尺寸 Dimensions(mm)			可选牌号 Grade For Choice												
		L	T	RE	TC420	TC422	TC520	TC521	TC522	TC620	TC622	TP621	TP622	TP624	TP721	TP722	TP724
	APKT1003PDER-HM90	10.39	3.53	0.8								○	★	☆			

★主推牌号 Primary brand number ☆可选牌号 Optional brand ○按订单生产 Production to order

产品 Inserts Shape	型号 Type	尺寸 Dimensions(mm)			可选牌号 Grade For Choice												
		L	T	RE	TC420	TC422	TC520	TC521	TC522	TC620	TC622	TP621	TP622	TP624	TP721	TP722	TP724
	APKT11T308-PM	10.22	6.478	0.8								○	★	☆			
	APKT160408-PM	15.30	4.76	0.8								○	★	☆			

★主推牌号 Primary brand number ☆可选牌号 Optional brand ○按订单生产 Production to order

B 铣削刀片 Milling Insert

MIATI TOOLS

Milling Insert And
Turning Insert Tools

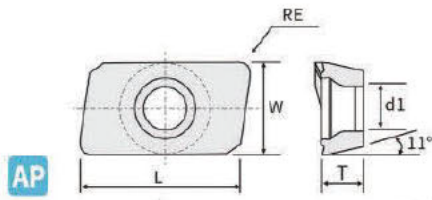

AP

		尺寸 Dimensions(mm)					可选牌号 Grade For Choice											
产品 Inserts Shape	型号 Type	L	W	T	d1	RE	TC420	TC422	TC520	TC521	TC522	TC620	TC622	TP621	TP622	TP721	TP722	TP724
	APMT1135PDER-TT	11.25	6.20	3.50	2.80	0.8							○	★	☆			
	APMT1604PDER-TT	17.25	9.25	4.76	4.40	0.8							○	★	☆			

★主推牌号Primary brand number ☆可选牌号Optional brand ○按订单生产Production to order

		尺寸 Dimensions(mm)					可选牌号 Grade For Choice											
产品 Inserts Shape	型号 Type	L	W	T	d1	RE	TC420	TC422	TC520	TC521	TC522	TC620	TC622	TP621	TP622	TP721	TP722	TP724
	APMT1135PDER-M2	11.25	6.20	3.50	2.80	0.8							○	★	☆			
	APMT1604PDER-M2	17.25	9.25	4.76	4.40	0.8							○	★	☆			

★主推牌号Primary brand number ☆可选牌号Optional brand ○按订单生产Production to order

B 铣削刀片 Milling Insert

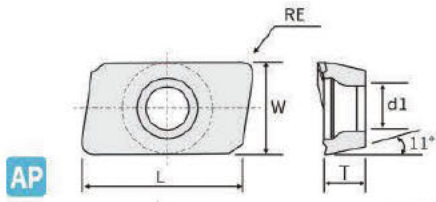

产品 Inserts Shape	型号 Type	尺寸 Dimensions(mm)					可选牌号 Grade For Choice													
		L	W	T	d1	RE	TC420	TC422	TC520	TC521	TC522	TC620	TC622	TP621	TP622	TP624	TP721	TP722	TP724	
	APMT1135PDER-H2	11.25	6.20	3.50	2.80	0.8								○	★	☆				
	APMT1604PDER-H2	17.25	9.25	4.76	4.40	0.8								○	★	☆				

★主推牌号Primary brand number ☆可选牌号Optional brand ○按订单生产Production to order

产品 Inserts Shape	型号 Type	尺寸 Dimensions(mm)					可选牌号 Grade For Choice													
		L	W	T	d1	RE	TC420	TC422	TC520	TC521	TC522	TC620	TC622	TP621	TP622	TP624	TP721	TP722	TP724	
	APMT1705PER-EM	18.50	10.70	5.56	4.42	0.8								○	★	☆				

★主推牌号Primary brand number ☆可选牌号Optional brand ○按订单生产Production to order

B 铣削刀片 Milling Insert

MIATI TOOLS

Milling Insert And
Turning Insert Tools

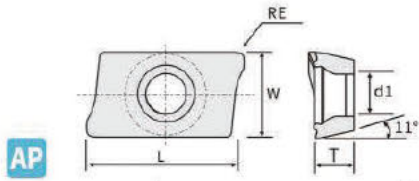

AP

产品 Inserts Shape	型号 Type	尺寸 Dimensions(mm)			可选牌号 Grade For Choice												
		L	T	RE	TC420	TC422	TC520	TC521	TC522	TC620	TC622	TP621	TP622	TP624	TP721	TP722	TP724
	APMT113502(APKT)	11.45	3.52	0.2								○	★	☆			
	APMT113504(APKT)	11.45	3.52	0.4								○	★	☆			
	APMT113512(APKT)	11.45	3.52	1.2								○	★	☆			
	APMT113516(APKT)	11.45	3.52	1.6								○	★	☆			
	APMT113520(APKT)	11.45	3.52	2.0								○	★	☆			

★主推牌号Primary brand number ☆可选牌号Optional brand ○按订单生产Production to order

产品 Inserts Shape	型号 Type	尺寸 Dimensions(mm)			可选牌号 Grade For Choice												
		L	T	RE	TC420	TC422	TC520	TC521	TC522	TC620	TC622	TP621	TP622	TP624	TP721	TP722	TP724
	APMT160402(APKT)	15.30	4.76	0.2								○	★	☆			
	APMT160404(APKT)	15.30	4.76	0.4								○	★	☆			
	APMT160406(APKT)	15.30	4.76	0.6								○	★	☆			
	APMT160410(APKT)	15.30	4.76	1.0								○	★	☆			
	APMT160412(APKT)	15.30	4.76	1.2								○	★	☆			
	APMT160416(APKT)	15.30	4.76	1.6								○	★	☆			

★主推牌号Primary brand number ☆可选牌号Optional brand ○按订单生产Production to order

B 铣削刀片 Milling Insert

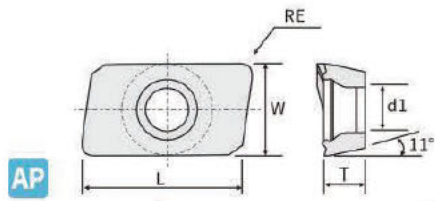

AP

尺寸 Dimensions(mm)

可选牌号 Grade For Choice

产品 Inserts Shape	型号 Type	L	T	RE	可选牌号 Grade For Choice												
					TC420	TC422	TC520	TC521	TC522	TC620	TC622	TP621	TP622	TP624	TP721	TP722	TP724
	APMT160420(APKT)	15.30	4.76	2.0								○	★	☆			
	APMT160424(APKT)	15.30	4.76	2.4								○	○	★	☆		
	APMT160425(APKT)	15.30	4.76	2.5								○	○	★	☆		
	APMT160430(APKT)	15.30	4.76	3.0								○	○	★	☆		
	APMT160440(APKT)	15.30	4.76	4.0								○	○	★	☆		

★主推牌号Primary brand number ☆可选牌号Optional brand ○按订单生产Production to order

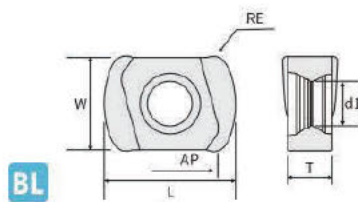

BL

尺寸 Dimensions(mm)

可选牌号 Grade For Choice

产品 Inserts Shape	型号 Type	L	W	T	AP	RE	可选牌号 Grade For Choice										
							TC420	TC422	TC520	TC521	TC522	TC620	TC622	TP621	TP622	TP624	TP721
	BLMP0603R-M	9.00	6.40	3.73	1	6								○	★	☆	
	BLMP0904R-M	11.90	9.18	4.80	1.5	8								○	★	☆	

★主推牌号Primary brand number ☆可选牌号Optional brand ○按订单生产Production to order

B 铣削刀片 Milling Insert

MIATI TOOLS

Milling Insert And
Turning Insert Tools

BD

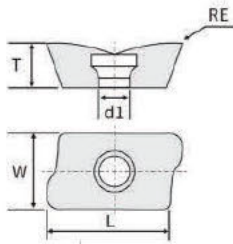

产品 Inserts Shape	型号 Type	尺寸 Dimensions(mm)					可选牌号 Grade For Choice													
		L	W	T	d1	RE	TC420	TC422	TC520	TC521	TC522	TC620	TC622	TP621	TP622	TP624	TP721	TP722	TP724	
	BDMT11T308ER-JT	11.0	6.7	3.8	2.8	0.8								○	★	☆				

★主推牌号 Primary brand number ☆可选牌号 Optional brand ○按订单生产 Production to order

EP

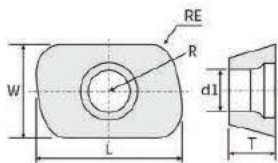

产品 Inserts Shape	型号 Type	尺寸 Dimensions(mm)					可选牌号 Grade For Choice													
		L	W	R	T	RE	TC420	TC422	TC520	TC521	TC522	TC620	TC622	TP621	TP622	TP624	TP721	TP722	TP724	
	EPMT0603TN	10.00	6.35	8	3.18	2.8								○	★	☆				
	EPNW0603TN-8	10.00	6.35	8	3.18	2.8								○	★	☆				

★主推牌号 Primary brand number ☆可选牌号 Optional brand ○按订单生产 Production to order

B 铣削刀片 Milling Insert

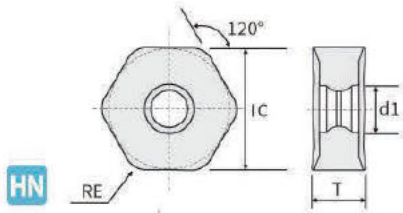

尺寸 Dimensions(mm)

可选牌号 Grade For Choice

产品 Inserts Shape	型号 Type	IC	T	d1	TC420	TC422	TC520	TC521	TC522	TC620	TC622	TP621	TP622	TP624	TP721	TP722	TP724
	HNMG090GANSN-M(HNMX)	16.5	6.35	4.90								○	★ ☆				
	HNMG090GANSN-R(HNMX)	16.5	6.35	4.90								○	★ ☆				

★主推牌号Primary brand number ☆可选牌号Optional brand ○按订单生产Production to order

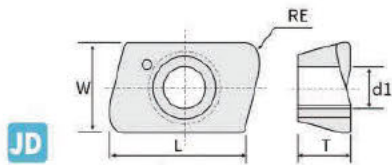

尺寸 Dimensions(mm)

可选牌号 Grade For Choice

产品 Inserts Shape	型号 Type	L	W	d1	RE	TC420	TC422	TC520	TC521	TC522	TC620	TC622	TP621	TP622	TP624	TP721	TP722	TP724
	JDMT070204R	6.40	4.30	2.15	0.40								○	★ ☆				
	JDMT070208R	6.40	4.30	2.15	0.80								○	★ ☆				

★主推牌号Primary brand number ☆可选牌号Optional brand ○按订单生产Production to order

B 铣削刀片 Milling Insert

MIATI TOOLS

Milling Insert And
Turning Insert Tools

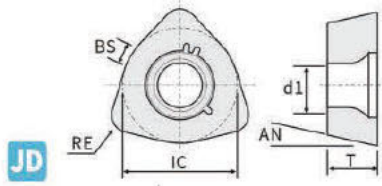

JD

产品 Inserts Shape	型号 Type	尺寸 Dimensions(mm)					可选牌号 Grade For Choice												
		IC	T	BS	AN	RE	TC420	TC422	TC520	TC521	TC522	TC620	TC622	TP621	TP622	TP624	TP721	TP722	TP724
	JDMW120420SR-FT	12.00	4.76	2.50	15°	2.00								○	★ ☆				
	JDMW140520SR-FT	14.00	5.56	2.80	15°	2.00								○	★ ☆				

★主推牌号Primary brand number ☆可选牌号Optional brand ○按订单生产Production to order

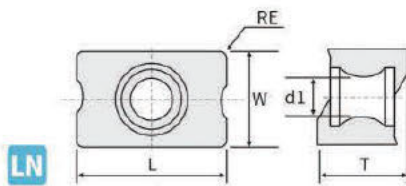

LN

产品 Inserts Shape	型号 Type	尺寸 Dimensions(mm)					可选牌号 Grade For Choice												
		L	W	T	d1	RE	TC420	TC422	TC520	TC521	TC522	TC620	TC622	TP621	TP622	TP624	TP721	TP722	TP724
	LNMX100605PNR-MM	10.0	6.5	6.5	3.5	0.5								○	★ ☆				
	LNMX151008PNR-MM	15.0	10.0	10.0	4.5	0.8								○	★ ☆				

★主推牌号Primary brand number ☆可选牌号Optional brand ○按订单生产Production to order

B 铣削刀片 Milling Insert

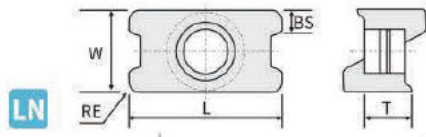

LN

尺寸 Dimensions(mm)

可选牌号 Grade For Choice

产品 Inserts Shape	型号 Type	L	W	T	RE	TC420	TC422	TC520	TC521	TC522	TC620	TC622	TP621	TP622	TP624	TP721	TP722	TP724	
	LNPU110408SRGE	12.1	6.6	4.83	0.9								○	★	☆				
	LNPU15T608SRGE	16.9	10	6.96	1.8								○	★	☆				

★主推牌号 Primary brand number ☆可选牌号 Optional brand ○按订单生产 Production to order

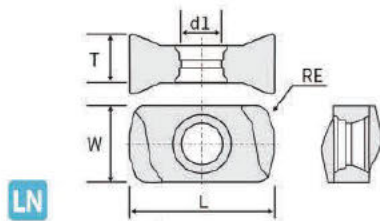

LN

尺寸 Dimensions(mm)

可选牌号 Grade For Choice

产品 Inserts Shape	型号 Type	L	W	T	d1	RE	TC420	TC422	TC520	TC521	TC522	TC620	TC622	TP621	TP622	TP624	TP721	TP722	TP724	
	LNMMU0303ZER-MJ	11.90	6.00	3.75	2.85	1.2								○	★	☆				

★主推牌号 Primary brand number ☆可选牌号 Optional brand ○按订单生产 Production to order

B 铣削刀片 Milling Insert

MIATI TOOLS

Milling Insert And Turning Insert Tools

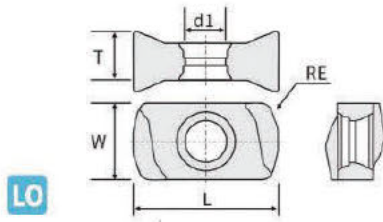

尺寸 Dimensions(mm)

可选牌号 Grade For Choice

产品 Inserts Shape	型号 Type	L	W	T	d1	RE	可选牌号 Grade For Choice														
							TC420	TC422	TC520	TC521	TC522	TC620	TC622	TP621	TP622	TP624	TP721	TP722	TP724		
	LOGU030310ER-GM	11.90	6.20	3.96	3.45	1.0								○	★	☆					

★主推牌号 Primary brand number ☆可选牌号 Optional brand ○按订单生产 Production to order

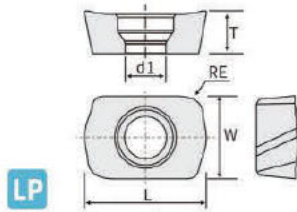

尺寸 Dimensions(mm)

可选牌号 Grade For Choice

产品 Inserts Shape	型号 Type	L	W	T	d1	RE	可选牌号 Grade For Choice														
							TC420	TC422	TC520	TC521	TC522	TC620	TC622	TP621	TP622	TP624	TP721	TP722	TP724		
	LPGT010210ER	6.26	4.19	2.19	2.10	1								○	★	☆					

★主推牌号 Primary brand number ☆可选牌号 Optional brand ○按订单生产 Production to order

B 铣削刀片 Milling Insert

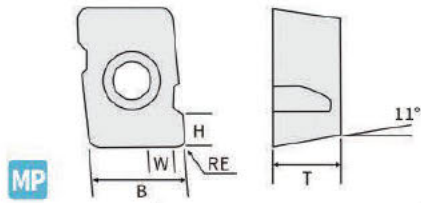

MP

产品 Inserts Shape	型号 Type	尺寸 Dimensions(mm)					可选牌号 Grade For Choice												
		B	W	T	H	RE	TC420	TC422	TC520	TC521	TC522	TC620	TC622	TP621	TP622	TP721	TP722	TP724	
	MPHW060304ZEL	6.35	0.5	3.18	3	0.4								○	★	☆			
	MPHW060308ZEL	6.35	0.5	3.18	3	0.8								○	★	☆			
	MPHW060304ZEL-0.5	6.35	0.5	3.18	3	0.4								○	★	☆			
	MPHW060308ZEL-1.5	6.35	1.5	3.18	3	0.8								○	★	☆			

★主推牌号 Primary brand number ☆可选牌号 Optional brand ○按订单生产 Production to order

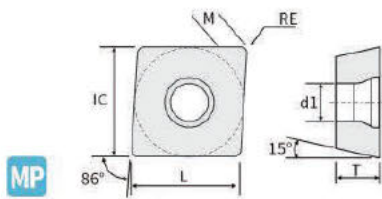

MP

产品 Inserts Shape	型号 Type	尺寸 Dimensions(mm)					可选牌号 Grade For Choice												
		L	IC	T	d1	RE	TC420	TC422	TC520	TC521	TC522	TC620	TC622	TP621	TP622	TP721	TP722	TP724	
	MPHT060304-DM	6.35	6.35	3.18	2.8	0.4								○	★	☆			
	MPHT080305-DM	8.3	8.3	3.18	3.4	0.5								○	★	☆			
	MPHT120408-DM	12.7	12.7	4.76	5.56	0.8								○	★	☆			

★主推牌号 Primary brand number ☆可选牌号 Optional brand ○按订单生产 Production to order

B 铣削刀片 Milling Insert

MIATI TOOLS

Milling Insert And
Turning Insert Tools

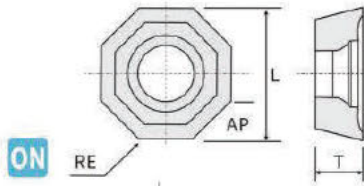

产品 Inserts Shape	型号 Type	尺寸 Dimensions(mm)				可选牌号 Grade For Choice													
		L	AP	T	RE	TC420	TC422	TC520	TC521	TC522	TC620	TC622	TP621	TP622	TP624	TP721	TP722	TP724	
	ODMT0605ANN-MM	15.875	-	5.56	0.8									○	★	☆			

★主推牌号Primary brand number ☆可选牌号Optional brand ○按订单生产Production to order

ON

产品 Inserts Shape	型号 Type	尺寸 Dimensions(mm)				可选牌号 Grade For Choice													
		L	AP	T	RE	TC420	TC422	TC520	TC521	TC522	TC620	TC622	TP621	TP622	TP624	TP721	TP722	TP724	
	ODMT0605ANN-MR	15.875	-	5.56	0.8									○	★	☆			

★主推牌号Primary brand number ☆可选牌号Optional brand ○按订单生产Production to order

B 铣削刀片 Milling Insert

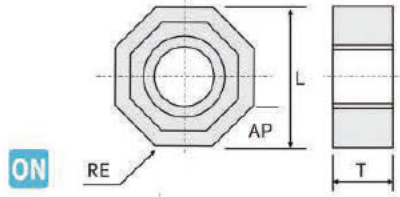

产品 Inserts Shape	型号 Type	尺寸 Dimensions(mm)				可选牌号 Grade For Choice													
		L	AP	T	RE	TC420	TC422	TC520	TC521	TC522	TC620	TC622	TP621	TP622	TP624	TP721	TP722	TP724	
	ONMU050505	13.00	3.50	5.08	0.5									○	★	☆			
	ONMU080608	20.20	5.50	6.00	0.8									○	★	☆			

★主推牌号 Primary brand number ☆可选牌号 Optional brand ○按订单生产 Production to order

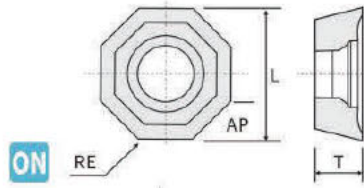

产品 Inserts Shape	型号 Type	尺寸 Dimensions(mm)				可选牌号 Grade For Choice													
		L	AP	T	RE	TC420	TC422	TC520	TC521	TC522	TC620	TC622	TP621	TP622	TP624	TP721	TP722	TP724	
	OFCT05T3TN-EM	12.7	3.50	3.80	0.6									○	★	☆			

★主推牌号 Primary brand number ☆可选牌号 Optional brand ○按订单生产 Production to order

B 铣削刀片 Milling Insert

MIATI TOOLS

Milling Insert And
Turning Insert Tools

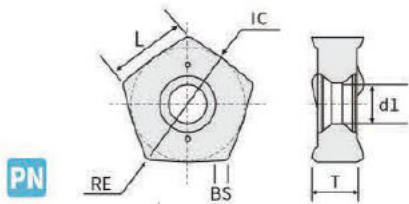

产品 Inserts Shape	型号 Type	尺寸 Dimensions(mm)					可选牌号 Grade For Choice													
		L	IC	T	BS	RE	TC420	TC422	TC520	TC521	TC522	TC620	TC622	TP621	TP622	TP624	TP721	TP722	TP724	
	PNMU0905GNEN-MJ	8.90	12.20	6.00	1.40	0.8								○	★	☆				

★主推牌号Primary brand number ☆可选牌号Optional brand ○按订单生产Production to order

产品 Inserts Shape	型号 Type	尺寸 Dimensions(mm)					可选牌号 Grade For Choice													
		L	IC	T	BS	RE	TC420	TC422	TC520	TC521	TC522	TC620	TC622	TP621	TP622	TP624	TP721	TP722	TP724	
	PNMU0905XNER-GM	8.90	12.20	6.00	1.40	0.8								○	★	☆				

★主推牌号Primary brand number ☆可选牌号Optional brand ○按订单生产Production to order

B 铣削刀片 Milling Insert

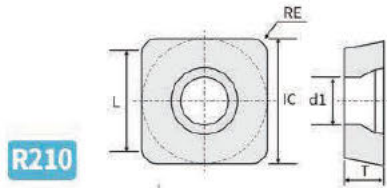

		尺寸 Dimensions(mm)						可选牌号 Grade For Choice												
产品 Inserts Shape	型号 Type	L	IC	T	d1	BS	RE	TC420	TC422	TC520	TC521	TC522	TC620	TC622	TP621	TP622	TP624	TP721	TP722	TP724
	R210-0904-14E-PM	5.77	9.5	4.5	4.2	0.66	1.4						★		★	○				

★主推牌号Primary brand number ☆可选牌号Optional brand ○按订单生产Production to order

		尺寸 Dimensions(mm)						可选牌号 Grade For Choice												
产品 Inserts Shape	型号 Type	L	IC	T	d1	BS	RE	TC420	TC422	TC520	TC521	TC522	TC620	TC622	TP621	TP622	TP624	TP721	TP722	TP724
	R210-1405 12M-KM	11.30	14.5	4.76	5.7	0.77	1						★		★	○				

★主推牌号Primary brand number ☆可选牌号Optional brand ○按订单生产Production to order

B 铣削刀片 Milling Insert

MIATI TOOLS

Milling Insert And
Turning Insert Tools

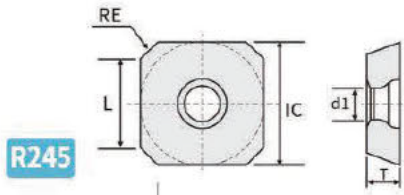

尺寸 Dimensions(mm)

可选牌号 Grade For Choice

产品 Inserts Shape	型号 Type	L	IC	T	d1	RE	可选牌号 Grade For Choice												
							TC420	TC422	TC520	TC521	TC522	TC620	TC622	TP621	TP622	TP624	TP721	TP722	TP724
	R245-12T3M-PM	10	13.4	3.97	4.1	1.5							★	★	○				

★主推牌号Primary brand number ☆可选牌号Optional brand ○按订单生产Production to order

产品 Inserts Shape	型号 Type	L	IC	T	d1	RE	可选牌号 Grade For Choice												
							TC420	TC422	TC520	TC521	TC522	TC620	TC622	TP621	TP622	TP624	TP721	TP722	TP724
	R245-18T6 M-MM	13.9	18	6.1	5.7	1							★	★	○				

★主推牌号Primary brand number ☆可选牌号Optional brand ○按订单生产Production to order

B 铣削刀片 Milling Insert

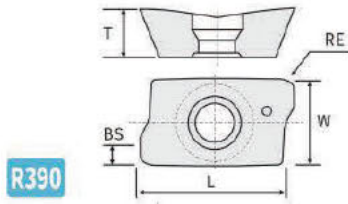

产品 Inserts Shape	型号 Type	尺寸 Dimensions(mm)					可选牌号 Grade For Choice													
		L	W	T	BS	RE	TC420	TC422	TC520	TC521	TC522	TC620	TC622	TP621	TP622	TP624	TP721	TP722	TP724	
	R390-11T304M-PM	10	6.8	3.59	0.9	0.4							○		☆	★				
	R390-11T308M-PM	10	6.8	3.59	1.2	0.8							○		☆	★				
	R390-11T316E-PM	11	6.8	3.59	0.4	1.6							○		☆	★				
	R390-11T320E-PM	11	6.8	3.59	-	2.0							○		☆	★				

★主推牌号Primary brand number ☆可选牌号Optional brand ○按订单生产Production to order

产品 Inserts Shape	型号 Type	尺寸 Dimensions(mm)					可选牌号 Grade For Choice													
		L	W	T	BS	RE	TC420	TC422	TC520	TC521	TC522	TC620	TC622	TP621	TP622	TP624	TP721	TP722	TP724	
	R390-170408M-PM	15.7	9.6	4.76	15	0.8							○		☆	★				

★主推牌号Primary brand number ☆可选牌号Optional brand ○按订单生产Production to order

B 铣削刀片 Milling Insert

MIATI TOOLS

Milling Insert And
Turning Insert Tools

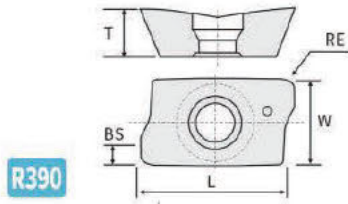

R390

产品 Inserts Shape	型号 Type	尺寸 Dimensions(mm)					可选牌号 Grade For Choice													
		L	W	T	BS	RE	TC420	TC422	TC520	TC521	TC522	TC620	TC622	TP621	TP622	TP624	TP721	TP722	TP724	
	R390-180608M-PM	15.4	11	6.33	1.1	0.8									○	☆	★			
	R390-180612M-PM	15.4	11	6.33	1.1	1.2									○	☆	★			

★主推牌号Primary brand number ☆可选牌号Optional brand ○按订单生产Production to order

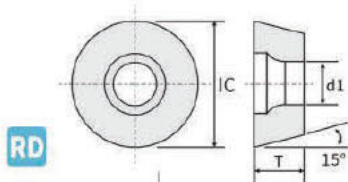

RD

产品 Inserts Shape	型号 Type	尺寸 Dimensions(mm)				可选牌号 Grade For Choice														
		IC	T	d1	A	TC420	TC422	TC520	TC521	TC522	TC620	TC622	TP621	TP622	TP624	TP721	TP722	TP724		
	RDMW1003MO	10.00	3.18	4.40	15°									○	★	☆				
	RDMW10T3MO	10.00	3.97	4.40	15°									○	★	☆				
	RDMW1204MO	12.00	4.76	4.40	15°									○	★	☆				

★主推牌号Primary brand number ☆可选牌号Optional brand ○按订单生产Production to order

B 铣削刀片 Milling Insert

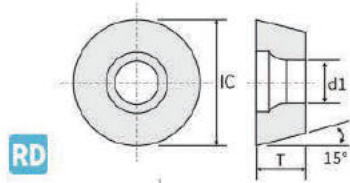

RD

产品 Inserts Shape	型号 Type	尺寸 Dimensions(mm)				可选牌号 Grade For Choice											
		IC	T	d1	A	TC420	TC422	TC520	TC521	TC522	TC620	TC622	TP621	TP622	TP721	TP722	TP724
	RDMT1204MO-A27	12.00	4.76	4.40	15°							○	★	☆			
	RDMT1605MOE-D57	16.00	5.76	5.50	15°							○	★	☆			

★主推牌号 Primary brand number ☆可选牌号 Optional brand ○按订单生产 Production to order

产品 Inserts Shape	型号 Type	尺寸 Dimensions(mm)				可选牌号 Grade For Choice											
		IC	T	d1	A	TC420	TC422	TC520	TC521	TC522	TC620	TC622	TP621	TP622	TP721	TP722	TP724
	RDMT0802MO-TN	8.00	2.58	3.40	15°							○	★	☆			
	RDMT10T3MO-TN	10.00	3.97	4.40	15°							○	★	☆			
	RDMT1204MO-TN	12.00	4.76	4.40	15°							○	★	☆			
	RDMT1604MO-TN	16.00	4.76	5.50	15°							○	★	☆			

★主推牌号 Primary brand number ☆可选牌号 Optional brand ○按订单生产 Production to order

B 铣削刀片 Milling Insert

MIATI TOOLS

Milling Insert And
Turning Insert Tools

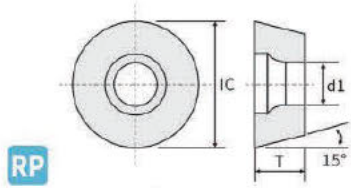

产品 Inserts Shape	型号 Type	尺寸 Dimensions(mm)				可选牌号 Grade For Choice												
		IC	T	d1	A	TC420	TC422	TC520	TC521	TC522	TC620	TC622	TP621	TP622	TP624	TP721	TP722	TP724
	RPMW08T2MO	8.00	2.58	2.94	15°									○	★	☆		
	RPMW1003MO	10.00	3.18	4.40	15°									○	★	☆		
	RPMW1204MO	12.00	4.76	4.40	15°									○	★	☆		

★主推牌号Primary brand number ☆可选牌号Optional brand ○按订单生产Production to order

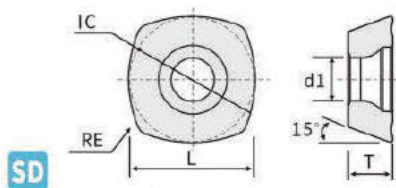

产品 Inserts Shape	型号 Type	尺寸 Dimensions(mm)				可选牌号 Grade For Choice												
		L	T	d1	RE	TC420	TC422	TC520	TC521	TC522	TC620	TC622	TP621	TP622	TP624	TP721	TP722	TP724
	SDMT09T307	8.92	3.60	3.40	0.7									○	★	☆		
	SDMT120512	12.70	5.56	4.40	1.2									○	★	☆		
	SDMT150512	15.875	5.56	5.50	1.2									○	★	☆		

★主推牌号Primary brand number ☆可选牌号Optional brand ○按订单生产Production to order

B 铣削刀片 Milling Insert

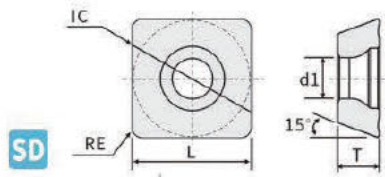

产品 Inserts Shape	型号 Type	尺寸 Dimensions(mm)				可选牌号 Grade For Choice													
		IC	T	d1	RE	TC420	TC422	TC520	TC521	TC522	TC620	TC622	TP621	TP622	TP624	TP721	TP722	TP724	
	SDMT09T312-DM	9.525	3.97	4.0	1.2									○	★	☆			
	SDMT120412-DM	12.7	4.76	4.4	1.2									○	★	☆			

★主推牌号Primary brand number ☆可选牌号Optional brand ○按订单生产Production to order

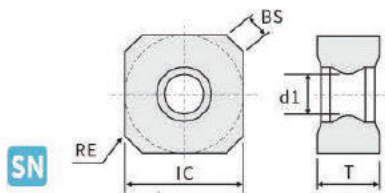

产品 Inserts Shape	型号 Type	尺寸 Dimensions(mm)				可选牌号 Grade For Choice													
		IC	T	BS	RE	TC420	TC422	TC520	TC521	TC522	TC620	TC622	TP621	TP622	TP624	TP721	TP722	TP724	
	SNMX1206ANN-MM	12.7	6.35	1.40	0.8									○	★	☆			
	SNMX1206QNN-MM	12.7	6.35	1.40	0.8									○	★	☆			

★主推牌号Primary brand number ☆可选牌号Optional brand ○按订单生产Production to order

B 铣削刀片 Milling Insert

MIATI TOOLS

Milling Insert And
Turning Insert Tools

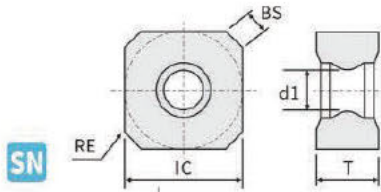

尺寸 Dimensions(mm)

可选牌号 Grade For Choice

产品 Inserts Shape	型号 Type	IC	T	BS	RE	可选牌号 Grade For Choice																					
						TC420	TC422	TC520	TC521	TC522	TC620	TC622	TP621	TP622	TP624	TP721	TP722	TP724									
	SNMX120412-DP	12.7	6.35	1.40	0.8										○	★	☆										

★主推牌号Primary brand number ☆可选牌号Optional brand ○按订单生产Production to order

产品 Inserts Shape	型号 Type	IC	T	BS	RE	可选牌号 Grade For Choice																					
						TC420	TC422	TC520	TC521	TC522	TC620	TC622	TP621	TP622	TP624	TP721	TP722	TP724									
	SNMX1206ANN-M	12.7	6.35	1.40	0.8										○	★	☆										
	SNMX1206ZNN-M	12.7	6.35	1.40	0.8										○	★	☆										

★主推牌号Primary brand number ☆可选牌号Optional brand ○按订单生产Production to order

B 铣削刀片 Milling Insert

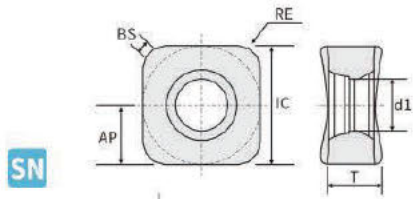

SN

尺寸 Dimensions(mm)

可选牌号 Grade For Choice

产品 Inserts Shape	型号 Type	IC	AP	T	BS	RE	TC420	TC422	TC520	TC521	TC522	TC620	TC622	TP621	TP622	TP721	TP722	TP724	
	SNMU1305ANTR-MM	13.0	6.0	6.50	3.0	0.8								○	★	☆			

★主推牌号 Primary brand number ☆可选牌号 Optional brand ○按订单生产 Production to order

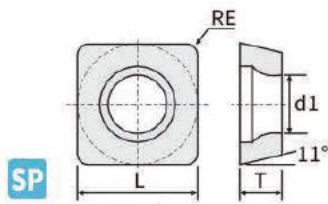

SP

尺寸 Dimensions(mm)

可选牌号 Grade For Choice

产品 Inserts Shape	型号 Type	L	T	A	RE	TC420	TC422	TC520	TC521	TC522	TC620	TC622	TP621	TP622	TP721	TP722	TP724	
	SPMT120408-D51	12.70	4.76	11°	0.8								○	★	☆			

★主推牌号 Primary brand number ☆可选牌号 Optional brand ○按订单生产 Production to order

B 铣削刀片 Milling Insert

MIATI TOOLS

Milling Insert And
Turning Insert Tools

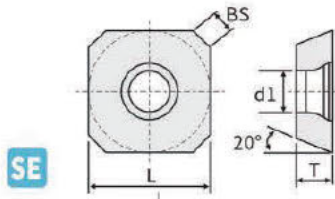

SE

尺寸 Dimensions(mm)

可选牌号 Grade For Choice

产品 Inserts Shape	型号 Type	L	IC	T	d1	BS	TC420	TC422	TC520	TC521	TC522	TC620	TC622	TP621	TP622	TP624	TP721	TP722	TP724	
	SEKT1204AFTN	12.7	12.7	4.76	5.16	2								○	★	☆				

★主推牌号Primary brand number ☆可选牌号Optional brand ○按订单生产Production to order

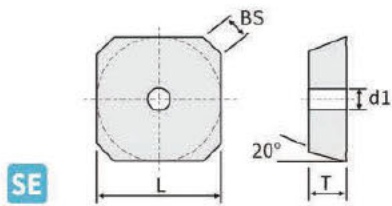

SE

尺寸 Dimensions(mm)

可选牌号 Grade For Choice

产品 Inserts Shape	型号 Type	L	IC	T	BS	TC420	TC422	TC520	TC521	TC522	TC620	TC622	TP621	TP622	TP624	TP721	TP722	TP724	
	SEKR1203AFTN	12.70	12.70	3.18	1.8								○	★	☆				
	SEKR1504AFTN	15.88	15.88	4.76	1.6								○	★	☆				

★主推牌号Primary brand number ☆可选牌号Optional brand ○按订单生产Production to order

B 铣削刀片 Milling Insert

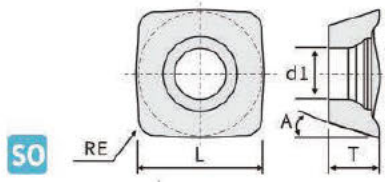

SO

尺寸 Dimensions(mm)

可选牌号 Grade For Choice

产品 Inserts Shape	型号 Type	L	T	d1	A	RE	可选牌号 Grade For Choice															
							TC420	TC422	TC520	TC521	TC522	TC620	TC622	TP621	TP622	TP624	TP721	TP722	TP724			
	SOMT100420ER-GM	10.30	4.58	4.60	16°	2.0																
	SOMT140520ER-GM	14.14	5.56	5.80	16°	2.0																

★主推牌号 Primary brand number ☆可选牌号 Optional brand ○按订单生产 Production to order

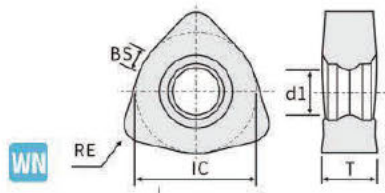

WN

尺寸 Dimensions(mm)

可选牌号 Grade For Choice

产品 Inserts Shape	型号 Type	IC	T	IN	RE	可选牌号 Grade For Choice																	
						TC420	TC422	TC520	TC521	TC522	TC620	TC622	TP621	TP622	TP624	TP721	TP722	TP724					
	WNMX060312ZNN-MM	6	3.18	1	1.2																		
	WNMX09T316ZNN-MM	9	3.97	1.5	1.6																		

★主推牌号 Primary brand number ☆可选牌号 Optional brand ○按订单生产 Production to order

B 铣削刀片 Milling Insert

MIATI TOOLS

Milling Insert And
Turning Insert Tools

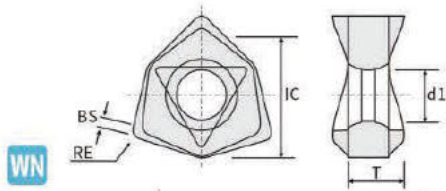

WN

尺寸 Dimensions(mm)

可选牌号 Grade For Choice

产品 Inserts Shape	型号 Type	IC	T	d1	RE	可选牌号 Grade For Choice											
						TC420	TC422	TC520	TC521	TC522	TC620	TC622	TP621	TP622	TP624	TP721	TP722
	WNMU040304ER-R	6.75	3.18	3.18	0.4							○	★	☆			
	WNMU060408ER-GM	10.15	4.36	4.20	0.8							○	★	☆			
	WNMU080608EN-GM	14.02	6.65	6.20	0.8							○	★	☆			

★主推牌号Primary brand number ☆可选牌号Optional brand ○按订单生产Production to order

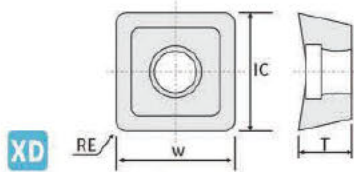

XD

尺寸 Dimensions(mm)

可选牌号 Grade For Choice

产品 Inserts Shape	型号 Type	W	T	RE	可选牌号 Grade For Choice												
					TC420	TC422	TC520	TC521	TC522	TC620	TC622	TP621	TP622	TP624	TP721	TP722	TP724
	XDMT120408	12.7	4.76	0.8								○	★	☆			

★主推牌号Primary brand number ☆可选牌号Optional brand ○按订单生产Production to order

B 铣削刀片 Milling Insert

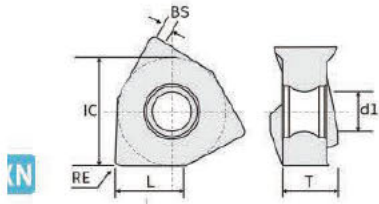

产品 Inserts Shape	型号 Type	尺寸 Dimensions(mm)					可选牌号 Grade For Choice												
		L	IC	T	BS	RE	TC420	TC422	TC520	TC521	TC522	TC620	TC622	TP621	TP622	TP624	TP721	TP722	TP724
	XNEX040304-TR	4.0	6.7	3.31	0.8	0.4								○	★	☆			
	XNEX080608-TR	7.5	12.48	6.45	1.3	0.8								○	★	☆			
	XNEX080608TR-M08	7.5	12.48	6.45	1.3	0.8								○	★	☆			
	XNEX080608TR-MD15	7.5	12.48	6.45	1.3	0.8								○	★	☆			
	XNEX080608TR-ME09	7.5	12.48	6.45	1.3	0.8								○	★	☆			
	XNEX080608TR-M13	7.5	12.48	6.45	1.3	0.8								○	★	☆			

★主推牌号Primary brand number ☆可选牌号Optional brand ○按订单生产Production to order

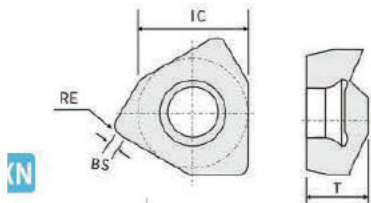

产品 Inserts Shape	型号 Type	尺寸 Dimensions(mm)				可选牌号 Grade For Choice													
		IC	T	BS	RE	TC420	TC422	TC520	TC521	TC522	TC620	TC622	TP621	TP622	TP624	TP721	TP722	TP724	
	XNKT060405PNSR-MM	5.7	4	1.3	0.5									○	★	☆			
	XNKT080508PNSR-MM	8.2	5.5	2.2	0.8									○	★	☆			

★主推牌号Primary brand number ☆可选牌号Optional brand ○按订单生产Production to order

B 铣削刀片 Milling Insert

MIATI TOOLS

Milling Insert And
Turning Insert Tools

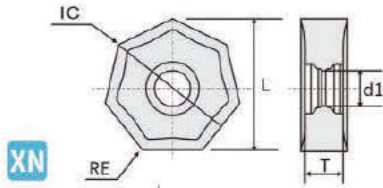

XN

尺寸 Dimensions(mm)

可选牌号 Grade For Choice

产品 Inserts Shape	型号 Type	L	IC	T	RE	TC420	TC422	TC520	TC521	TC522	TC620	TC622	TP621	TP622	TP624	TP721	TP722	TP724	
	XNMU070508-F57	15.2	14.5	5.4	0.8								○	★ ☆					
	XNMU070508-MM	15.2	14.5	5.4	0.8								○	★ ☆					

★主推牌号 Primary brand number ☆可选牌号 Optional brand ○按订单生产 Production to order

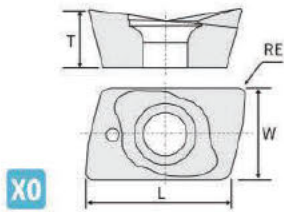

X0

尺寸 Dimensions(mm)

可选牌号 Grade For Choice

产品 Inserts Shape	型号 Type	L	W	T	RE	TC420	TC422	TC520	TC521	TC522	TC620	TC622	TP621	TP622	TP624	TP721	TP722	TP724	
	XOMX120408TR-ME08	12	8.18	4.15	0.8								○	★ ☆					

★主推牌号 Primary brand number ☆可选牌号 Optional brand ○按订单生产 Production to order

B 铣削刀片 Milling Insert

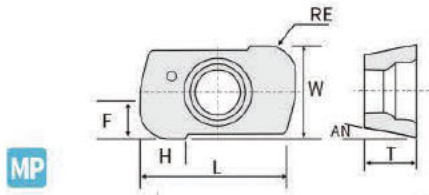

产品 Inserts Shape	型号 Type	尺寸 Dimensions(mm)					可选牌号 Grade For Choice													
		L	W	T	RE	A	TC420	TC422	TC520	TC521	TC522	TC620	TC622	TP621	TP622	TP624	TP721	TP722	TP724	
	YPHW100308ZER-15	10	6	3.35	0.3	11°							○	★	☆					

★主推牌号 Primary brand number ☆可选牌号 Optional brand ○按订单生产 Production to order

E精密磨制刀片 Precision boring Insert

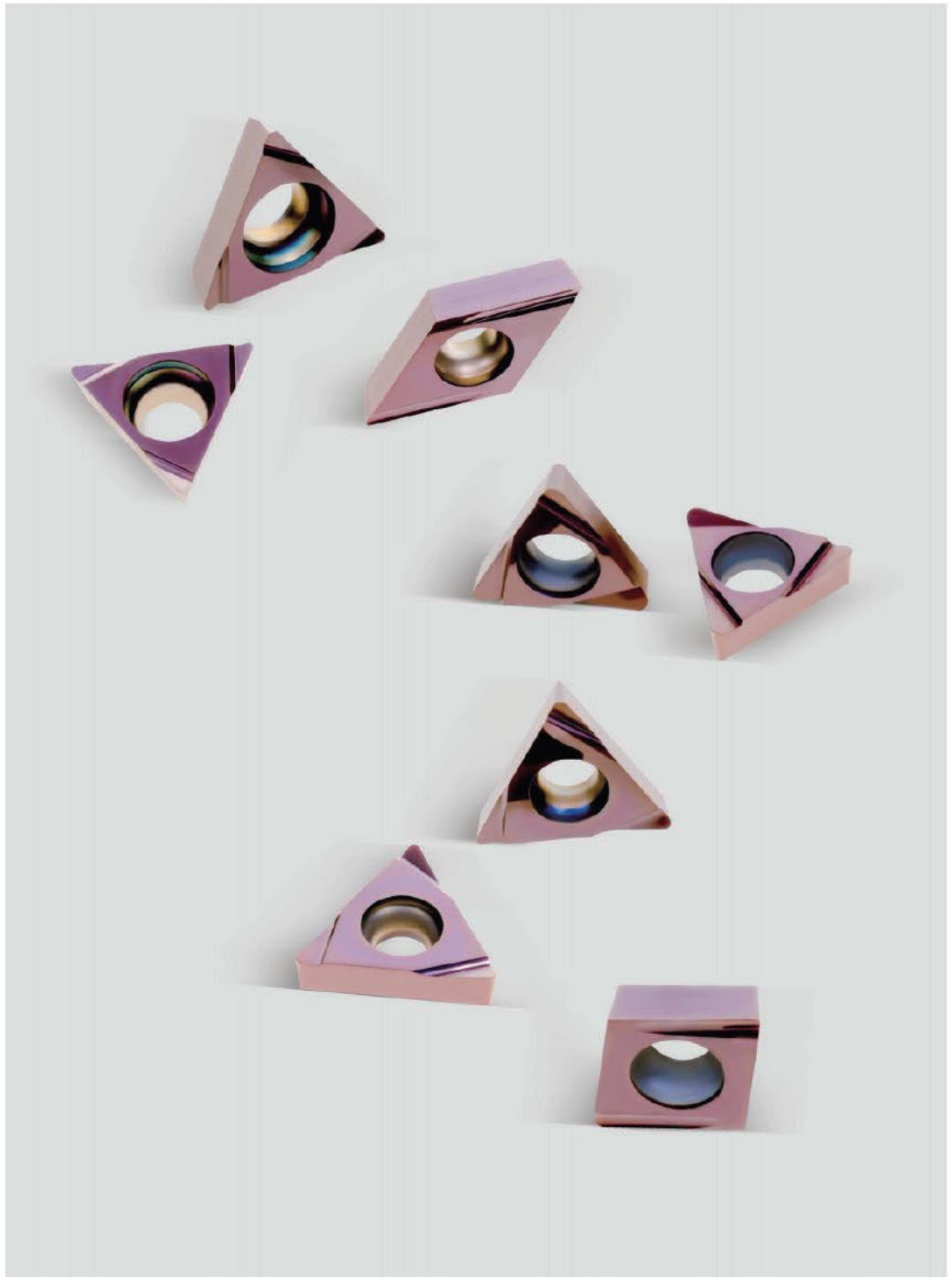

E精密磨制刀片 Precision boring insert

MIATI TOOLS

Milling Insert And
Turning Insert Tools

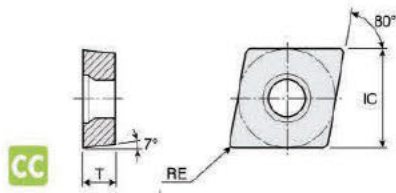

CC

尺寸 Dimensions(mm)

可选牌号 Grade For Choice

产品 Inserts Shape	型号 Type	IC	T	d1	RE	可选牌号 Grade For Choice		
						TP622	TP623	JT3000
	CCGT030102R/L	3.5	1.4	1.9	0.20		★	★
	CCGT030104R/L	3.5	1.4	1.9	0.40		★	★
	CCGT030201R/L	3.5	1.4	1.9	0.10		★	★
	CCGT030202R/L	3.5	1.4	1.9	0.20		★	★
	CCGT030204R/L	3.5	1.4	1.9	0.40		★	★
	CCGT040201R/L	4.3	1.8	2.3	0.10		★	★
	CCGT040202R/L	4.3	1.8	2.3	0.20		★	★
	CCGT040204R/L	4.3	1.8	2.3	0.40		★	★

★主推牌号 Primary brand number ☆可选牌号 Optional brand ○按订单生产 Production to order

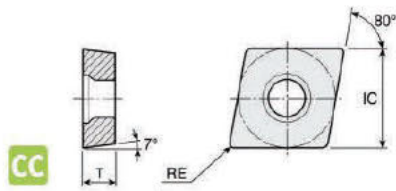

CC

尺寸 Dimensions(mm)

可选牌号 Grade For Choice

产品 Inserts Shape	型号 Type	IC	T	d1	RE	可选牌号 Grade For Choice		
						TP622	TP623	JT3000
	CCGT060201R/L	6.35	2.38	2.8	0.10		★	★
	CCGT060202R/L	6.35	2.38	2.8	0.20		★	★
	CCGT060204R/L	6.35	2.38	2.8	0.40		★	★
	CCGT09T301R/L	9.70	3.97	4.4	0.10		★	★
	CCGT09T302R/L	9.70	3.97	4.4	0.20		★	★
	CCGT09T304R/L	9.70	3.97	4.4	0.40		★	★
	CCGT09T308R/L	9.70	3.97	4.4	0.80		★	★

★主推牌号 Primary brand number ☆可选牌号 Optional brand ○按订单生产 Production to order

E精密磨制刀片 Precision boring Insert

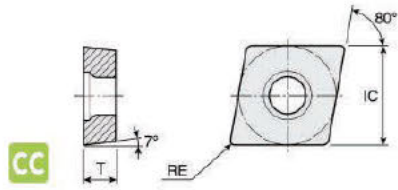

		尺寸 Dimensions(mm)				可选牌号 Grade For Choice		
产品 Inserts Shape	型号 Type	IC	T	d1	RE	TP622	TP623	JT3000
	CCGT060201-YL	6.35	2.38	2.8	0.10		★	★
	CCGT060202-YL	6.35	2.38	2.8	0.20		★	★
	CCGT060204-YL	6.35	2.38	2.8	0.40		★	★
	CCGT09T301-YL	9.70	3.97	4.4	0.10		★	★
	CCGT09T302-YL	9.70	3.97	4.4	0.20		★	★
	CCGT09T304-YL	9.70	3.97	4.4	0.40		★	★

★主推牌号 Primary brand number ☆可选牌号 Optional brand ○按订单生产 Production to order

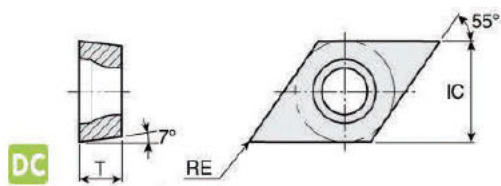

		尺寸 Dimensions(mm)					可选牌号 Grade For Choice		
产品 Inserts Shape	型号 Type	L	IC	T	d1	RE	TP622	TP623	JT3000
	DCGT070202R/L	7.80	6.35	2.38	2.80	0.20		★	★
	DCGT070204R/L	7.80	6.35	2.38	2.80	0.40		★	★
	DCGT11T302R/L	11.6	9.52	3.97	4.40	0.80		★	★
	DCGT11T304R/L	11.6	9.52	3.97	4.40	0.40		★	★
	DCGT11T308R/L	11.6	9.52	3.97	4.40	0.80		★	★

★主推牌号 Primary brand number ☆可选牌号 Optional brand ○按订单生产 Production to order

E精密磨制刀片 Precision boring insert

MIATI TOOLS

Milling Insert And
Turning Insert Tools

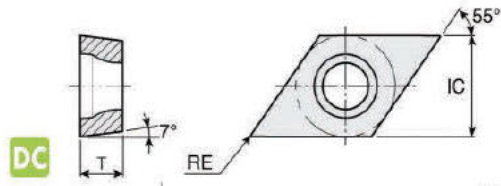

		尺寸 Dimensions(mm)					可选牌号 GradeForChoice		
产品 Inserts Shape	型号 Type	L	IC	T	d1	RE	TP622	TP623	JT3000
	DCGT070201-YL	7.80	6.35	2.38	2.80	0.10		★	★
	DCGT070202-YL	7.80	6.35	2.38	2.80	0.20		★	★
	DCGT070204-YL	7.80	6.35	2.38	2.80	0.40		★	★
	DCGT11T301-YL	11.6	9.52	3.97	4.40	0.80		★	★
	DCGT11T302-YL	11.6	9.52	3.97	4.40	0.40		★	★
	DCGT11T304-YL	11.6	9.52	3.97	4.40	0.80		★	★

★主推牌号Primary brand number ☆可选牌号Optional brand ○按订单生产Production to order

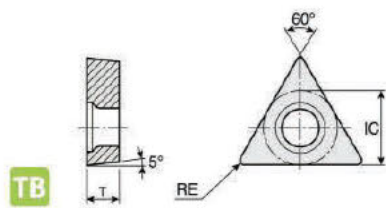

		尺寸 Dimensions(mm)				可选牌号 GradeForChoice		
产品 Inserts Shape	型号 Type	IC	T	H	AN	TP622	TP623	JT3000
	TBGT060104L	3.97	1.59	2.3	5°		★	★

★主推牌号Primary brand number ☆可选牌号Optional brand ○按订单生产Production to order

E精密磨制刀片 Precision boring Insert

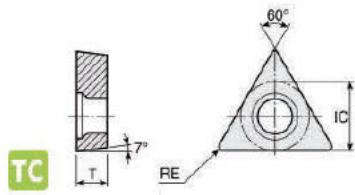

		尺寸 Dimensions(mm)				可选牌号 Grade For Choice		
产品 Inserts Shape	型号 Type	IC	T	H	AN	TP622	TP623	JT3000
	TCGT060102L	3.97	1.59	2.3	7°		★	★

★主推牌号 Primary brand number ☆可选牌号 Optional brand ○按订单生产 Production to order

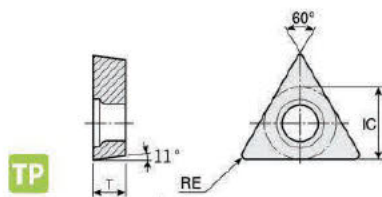

		尺寸 Dimensions(mm)				可选牌号 Grade For Choice		
产品 Inserts Shape	型号 Type	IC	T	H	AN	TP622	TP623	JT3000
	TPGH080202L	4.76	2.38	2.30	11°		★	★
	TPGH080204L	4.76	2.38	2.30	11°		★	★
	TPGH090202L	5.56	2.38	3.00	11°		★	★
	TPGH090204L	5.56	2.38	3.00	11°		★	★
	TPGH110202L	6.35	2.38	3.50	11°		★	★
	TPGH110204L	6.35	2.38	3.50	11°		★	★
	TPGH110302L	6.35	3.18	3.30	11°		★	★
	TPGH110304L	6.35	3.18	3.30	11°		★	★

★主推牌号 Primary brand number ☆可选牌号 Optional brand ○按订单生产 Production to order

E精密磨制刀片 Precision boring Insert

MIATI TOOLS

Milling Insert And
Turning Insert Tools

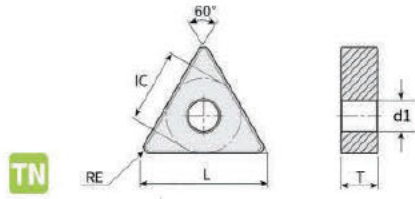

TN

尺寸 Dimensions(mm)

可选牌号 Grade For Choice

产品 Inserts Shape	型号 Type	L	IC	T	d1	RE	可选牌号 Grade For Choice		
							TP622	TP623	JT3000
	TNGG160402R/L-S/F	16.5	9.525	4.76	3.81	0.2		★	★
	TNGG160404R/L-S/F	16.5	9.525	4.76	3.81	0.4		★	★

★主推牌号 Primary brand number ☆可选牌号 Optional brand ○按订单生产 Production to order

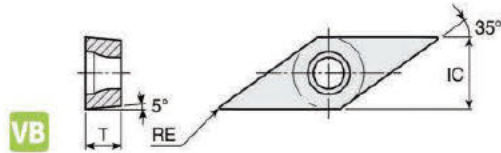

VB

尺寸 Dimensions(mm)

可选牌号 Grade For Choice

产品 Inserts Shape	型号 Type	IC	T	H	AN	可选牌号 Grade For Choice		
						TP622	TP623	JT3000
	VBGT110302R/L	6.35	3.18	2.8	5°		★	★
	VBGT110304R/L	6.35	3.18	2.8	5°		★	★

★主推牌号 Primary brand number ☆可选牌号 Optional brand ○按订单生产 Production to order

E精密磨制刀片 Precision boring Insert

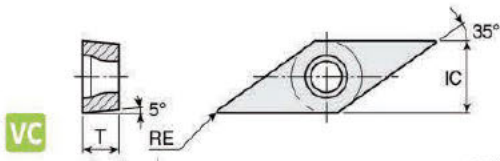

产品 Inserts Shape	型号 Type	尺寸 Dimensions(mm)				可选牌号 Grade For Choice		
		IC	T	H	AN	TP622	TP623	JT3000
	VCGT110301R/L	6.35	3.18	2.8	5°		★	★
	VCGT110302R/L	6.35	3.18	2.8	5°		★	★
	VCGT110304R/L	6.35	3.18	2.8	5°		★	★

★主推牌号 Primary brand number ☆可选牌号 Optional brand ○按订单生产 Production to order

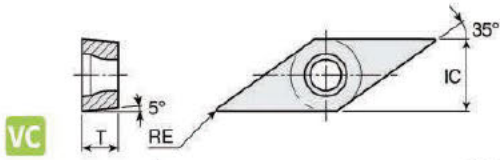

产品 Inserts Shape	型号 Type	尺寸 Dimensions(mm)				可选牌号 Grade For Choice		
		IC	T	H	AN	TP622	TP623	JT3000
	VCGT110301-YL	6.35	3.18	2.8	5°		★	★
	VCGT110302-YL	6.35	3.18	2.8	5°		★	★
	VCGT110304-YL	6.35	3.18	2.8	5°		★	★

★主推牌号 Primary brand number ☆可选牌号 Optional brand ○按订单生产 Production to order

E精密磨制刀片 Precision boring Insert

MIATI TOOLS

Milling Insert And
Turning Insert Tools

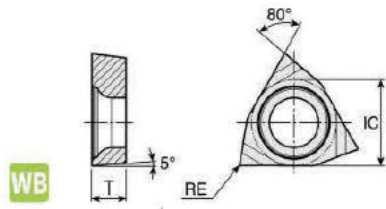

WB

尺寸 Dimensions(mm)

可选牌号 Grade For Choice

产品 Inserts Shape	型号 Type	IC	T	H	AN	TP622	TP623	JT3000
	WBG060102L	3.97	1.59	2.30	5°		★	★
	WBG060104L	3.97	1.59	2.30	5°		★	★

★主推牌号 Primary brand number ☆可选牌号 Optional brand ○按订单生产 Production to order

CARBIDE THREADED BLADES

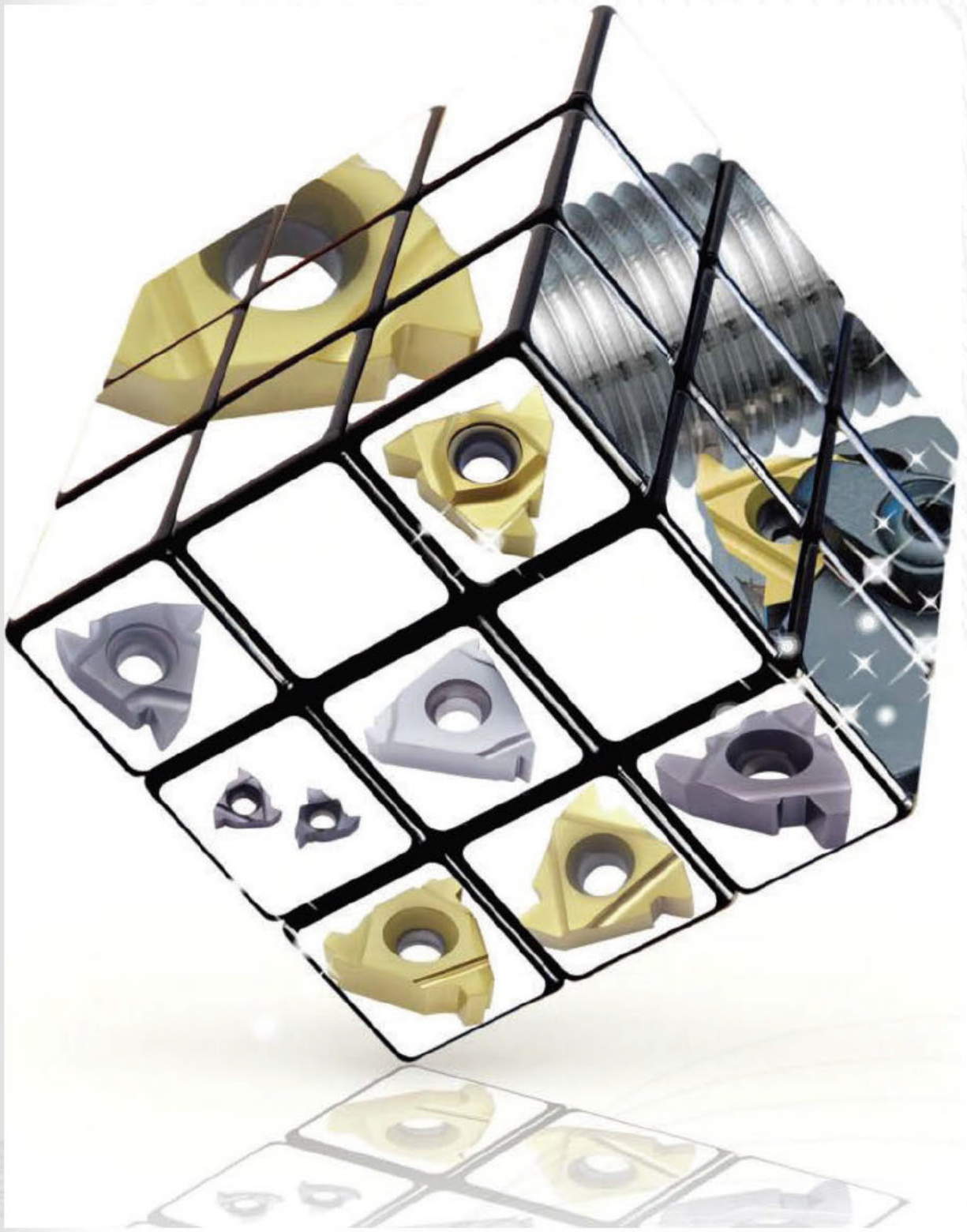

THREADING TOOLS

60° 通用型螺纹刀片 Partial Profile 60°

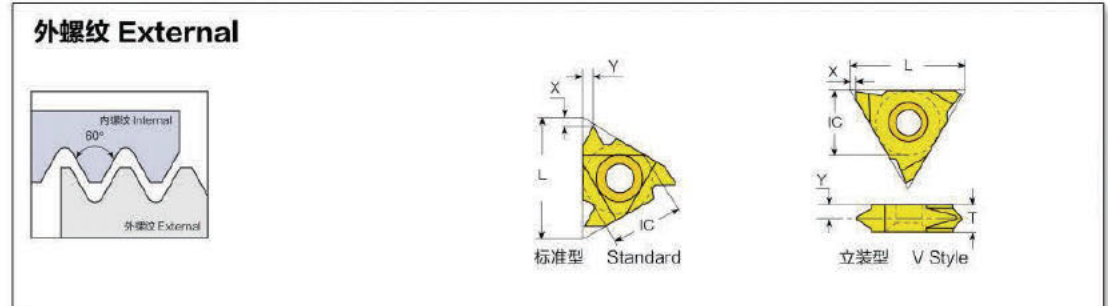

标准型 Standard

内切圆直径 Insert Size		加工螺距范围 Pitch		刀片型号 Ordering Code		刀片尺寸 Dimensions (mm)		
IC	L mm	mm	TPI	右旋螺纹 RH	左旋螺纹 LH	X	Y	T
1/4"	11	0.5~1.5	48~16	11ER A60	11EL A60	0.80	0.90	3.20
		0.5~1.5	48~16	16ER A60	16EL A60	0.80	0.90	3.65
3/8"	16	0.5~3.0	48~8	16ER AG60	16EL AG60	1.20	1.70	3.65
		1.75~3.0	14~8	16ER G60	16EL G60	1.20	1.70	3.65
1/2"	22	3.5~5.0	7~5	22ER N60	22EL N60	1.70	2.50	4.76
5/8"	27	5.5~6.0	4.5~4	27ER Q60	27EL Q60	2.10	3.10	6.35

立装型 V Style

内切圆直径 Insert Size		加工螺距范围 Pitch		刀片型号 Ordering Code		刀片尺寸 Dimensions (mm)		
IC	L mm	mm	TPI	右旋螺纹 RH	左旋螺纹 LH	X	Y	T
5/8"	27	6.0~10.0	4~2.5	27VER V60	27VEL V60	0.60	5.20	10.0

THREADING TOOLS

60° 通用型螺纹刀片 Partial Profile 60°

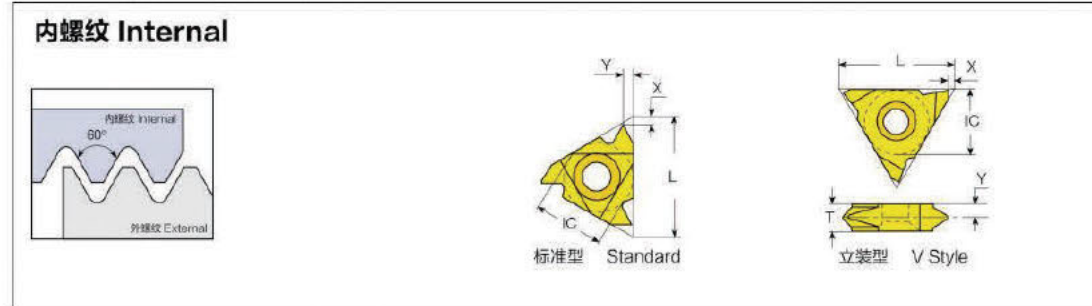

标准型 Standard

内切圆直径 Insert Size		加工螺距范围 Pitch		刀片型号 Ordering Code		刀片尺寸 Dimensions (mm)		
IC	L mm	mm	TPI	右旋螺纹 RH	左旋螺纹 LH	X	Y	T
5/32"	06	0.5~1.25	48~20	06NR A60	06NL A60	0.60	0.60	1.90
3/16"	08	0.5~1.5	48~16	08NR A60	08NL A60	0.60	0.70	2.20
1/4"	11	0.5~1.5	48~16	11NR A60	11NL A60	0.80	0.90	3.20
		0.5~1.5	48~16	16NR A60	16NL A60	0.80	0.90	3.65
		0.5~3.0	48~8	16NR AG60	16NL AG60	1.20	1.70	3.65
3/8"	16	1.75~3.0	14~8	16NR G60	16NL G60	1.20	1.70	3.65
		3.5~5.0	7~5	22NR N60	22NL N60	1.70	2.50	4.76
1/2"	22	3.5~5.0	7~5	22NR N60	22NL N60	1.70	2.50	4.76
5/8"	27	5.5~6.0	4.5~4	27NR Q60	27NL Q60	1.80	2.70	6.35

立装型 V Style

内切圆直径 Insert Size		加工螺距范围 Pitch		刀片型号 Ordering Code		刀片尺寸 Dimensions (mm)		
IC	L mm	mm	TPI	右旋螺纹 RH	左旋螺纹 LH	X	Y	T
5/8"	27	6.0~10.0	4~2.5	27VNR V60	27VNL V60	0.60	5.20	8.70

THREADING TOOLS

55° 通用型螺纹刀片 Partial Profile 55°

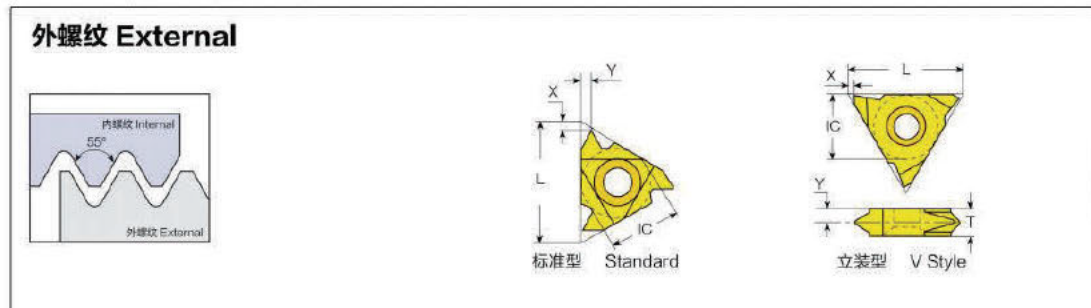

标准型 Standard

内切圆直径 Insert Size		加工螺距范围 Pitch		刀片型号 Ordering Code		刀片尺寸 Dimensions (mm)		
IC	L mm	mm	TPI	右旋螺纹 RH	左旋螺纹 LH	X	Y	T
1/4"	11	0.5~1.5	48~16	11ER A55	11EL A55	0.80	0.90	3.20
	16	0.5~1.5	48~16	16ER A55	16EL A55	0.80	0.90	3.65
3/8"	16	0.5~3.0	48~8	16ER AG55	16EL AG55	1.20	1.70	3.65
	16	1.75~3.0	14~8	16ER G55	16EL G55	1.20	1.70	3.65
1/2"	22	3.5~5.0	7~5	22ER N55	22EL N55	1.70	2.50	4.76
5/8"	27	5.5~6.0	4.5~4	27ER Q55	27EL Q55	2.00	2.90	6.35

立装型 V Style

内切圆直径 Insert Size		加工螺距范围 Pitch		刀片型号 Ordering Code		刀片尺寸 Dimensions (mm)		
IC	L mm	mm	TPI	右旋螺纹 RH	左旋螺纹 LH	X	Y	T
5/8"	27	6.0~9.0	4~2.5	27VER V55	27VEL V55	1.00	4.30	8.70

THREADING TOOLS

55° 通用型螺纹刀片 Partial Profile 55°

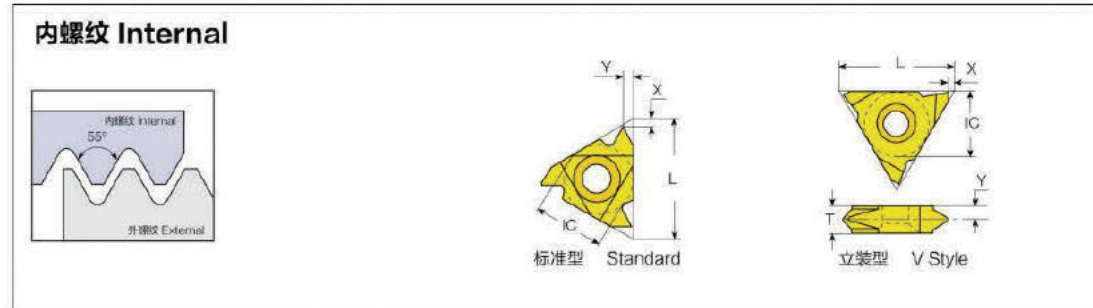

标准型 Standard

内切圆直径 Insert Size		加工螺距范围 Pitch		刀片型号 Ordering Code		刀片尺寸 Dimensions (mm)		
IC	L mm	mm	TPI	右旋螺纹 RH	左旋螺纹 LH	X	Y	T
5/32"	06	0.5~1.25	48~20	06NR A55	06NL A55	0.60	0.60	1.90
3/16"	08	0.5~1.5	48~16	08NR A55	08NL A55	0.60	0.70	2.20
1/4"	11	0.5~1.5	48~16	11NR A55	11NL A55	0.80	0.90	3.20
		0.5~1.5	48~16	16NR A55	16NL A55	0.80	0.90	3.65
3/8"	16	0.5~3.0	48~8	16NR AG55	16NL AG55	1.20	1.70	3.65
		1.75~3.0	14~8	16NR G55	16NL G55	1.20	1.70	3.65
		3.5~5.0	7~5	22NR N55	22NL N55	1.70	2.50	4.76
1/2"	22	3.5~5.0	7~5	22NR N55	22NL N55	1.70	2.50	4.76
5/8"	27	5.5~6.0	4.5~4	27NR Q55	27NL Q55	1.80	2.70	6.35

立装型 V Style

内切圆直径 Insert Size		加工螺距范围 Pitch		刀片型号 Ordering Code		刀片尺寸 Dimensions (mm)		
IC	L mm	mm	TPI	右旋螺纹 RH	左旋螺纹 LH	X	Y	T
5/8"	27	6.0~9.0	4~2.5	27VNR V55	27VNL V55	1.00	4.30	8.70

THREADING TOOLS

ISO标准型螺纹刀片 ISO Metric Full Profile

外螺纹 External

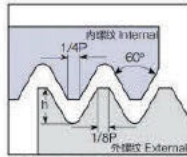

标准: R262 (DIN 13)
Defined by: R262 (DIN 13)
精度等级: 6g/6H
Tolerance class: 6g/6H

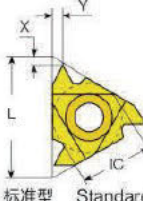

标准型 Standard

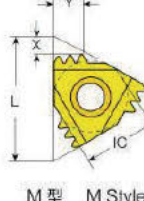

M型 M Style

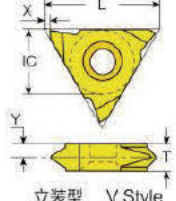

立装型 V Style

标准型 Standard

内切圆直径 Insert Size		加工螺距范围 Pitch	刀片型号 Ordering Code		刀片尺寸 Dimensions (mm)		
IC	L mm	mm	右旋螺纹 RH	左旋螺纹 LH	X	Y	T
1/4"	11	0.5	11ER0.50 ISO	11EL0.50 ISO	0.60	0.60	3.20
		0.75	11ER0.75 ISO	11EL0.75 ISO	0.60	0.60	3.20
		1.0	11ER1.00 ISO	11EL1.00 ISO	0.70	0.70	3.20
		1.25	11ER1.25 ISO	11EL1.25 ISO	0.80	0.90	3.20
		1.5	11ER1.50 ISO	11EL1.50 ISO	0.80	1.00	3.20
3/8"	16	1.75	11ER1.75 ISO	11EL1.75 ISO	0.80	1.10	3.20
		0.5	16ER0.50 ISO	16EL0.50 ISO	0.60	0.60	3.65
		0.75	16ER0.75 ISO	16EL0.75 ISO	0.60	0.60	3.65
		1.0	16ER1.00 ISO	16EL1.00 ISO	0.70	0.70	3.65
		1.25	16ER1.25 ISO	16EL1.25 ISO	0.80	0.90	3.65
		1.5	16ER1.50 ISO	16EL1.50 ISO	0.80	1.00	3.65
		1.75	16ER1.75 ISO	16EL1.75 ISO	0.90	1.20	3.65
		2.0	16ER2.00 ISO	16EL2.00 ISO	1.00	1.30	3.65
1/2"	22	2.5	16ER2.50 ISO	16EL2.50 ISO	1.10	1.50	3.65
		3.0	16ER3.00 ISO	16EL3.00 ISO	1.20	1.60	3.65
		3.5	22ER3.50 ISO	22EL3.50 ISO	1.60	2.30	4.76
		4.0	22ER4.00 ISO	22EL4.00 ISO	1.60	2.30	4.76
5/8"	27.5	4.5	22ER4.50 ISO	22EL4.50 ISO	1.70	2.40	4.76
		5.0	22ER5.00 ISO	22EL5.00 ISO	1.70	2.50	4.76
		5.5	27ER5.50 ISO	27EL5.50 ISO	1.90	2.70	6.35
		6.0	27ER6.00 ISO	27EL6.00 ISO	2.00	2.90	6.35

THREADING TOOLS

ISO标准型螺纹刀片(续) ISO Metric Full Profile (con't)

立装型 V Style

内切圆直径 Insert Size		加工螺距范围 Pitch	刀片型号 Ordering Code		刀片尺寸 Dimensions (mm)		
IC	L mm	mm	右旋螺纹 RH	左旋螺纹 LH	X	Y	T
3/8"	16	0.5	16VER0.50 ISO	16VEL0.50 ISO	1.10	3.00	3.65
		0.75	16VER0.75 ISO	16VEL0.75 ISO	1.10	3.00	3.65
		1.0	16VER1.00 ISO	16VEL1.00 ISO	1.10	2.90	3.65
		1.25	16VER1.25 ISO	16VEL1.25 ISO	1.10	2.70	3.65
		1.5	16VER1.50 ISO	16VEL1.50 ISO	1.10	2.60	3.65
		1.75	16VER1.75 ISO	16VEL1.75 ISO	1.10	2.50	3.65
		2.0	16VER2.00 ISO	16VEL2.00 ISO	1.10	2.30	3.65
		2.5	16VER2.50 ISO	16VEL2.50 ISO	1.10	2.10	3.65
		3.0	16VER3.00 ISO	16VEL3.00 ISO	1.10	2.00	3.65
5/8"	27	6.0	27VER6.00 ISO	27VEL6.00 ISO	1.00	3.30	6.35
		8.0	27VER8.00 ISO	27VEL8.00 ISO	1.00	4.30	8.70
		10.0	27VER10.0 ISO	27VEL10.0 ISO	1.00	5.20	10.0

梳齿型 M Style

内切圆直径 Insert Size		加工螺距范围 Pitch	刀片型号 Ordering Code		刀片尺寸 Dimensions (mm)		
IC	L mm	mm	右旋螺纹 RH	左旋螺纹 LH	X	Y	T
3/8"	16	1.0	16ER1.00 ISO3M		1.70	2.60	3.65
		1.5	16ER1.50 ISO2M		1.60	2.40	3.65
1/2"	22	1.5	22ER1.50 ISO3M		2.40	3.80	4.76
		2.0	22ER2.00 ISO2M		2.00	3.00	4.76
		2.0	22ER2.00 ISO3M		3.10	4.90	4.76
5/8"	27	3.0	27ER3.00 ISO2M		2.70	4.30	6.35

THREADING TOOLS

ISO标准型螺纹刀片 ISO Metric Full Profile

内螺纹 Internal

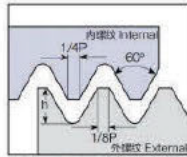

标准: R262 (DIN 13)
Defined by: R262 (DIN 13)
精度等级: 6g/6H
Tolerance class: 6g/6H

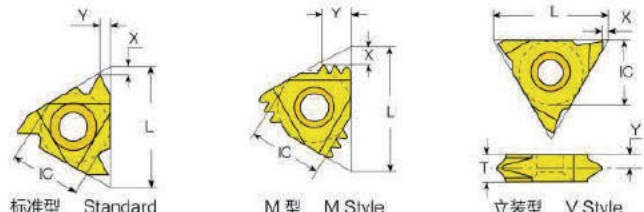

标准型 Standard
M型 M Style
立装型 V Style

标准型 Standard

内切圆直径 Insert Size		加工螺距范围 Pitch		刀片型号 Ordering Code		刀片尺寸 Dimensions (mm)		
IC	L mm	mm		右旋螺纹 RH	左旋螺纹 LH	X	Y	T
5/32"	6	0.5		06NR0.50 ISO	06NL0.50 ISO	0.90	0.50	1.90
		0.75		06NR0.75 ISO	06NL0.75 ISO	0.80	0.50	1.90
		1.0		06NR1.00 ISO	06NL1.00 ISO	0.70	0.60	1.90
		1.25		06NR1.25 ISO	06NL1.25 ISO	0.60	0.60	1.90
3/16"	8	0.5		08NR0.50 ISO	08NL0.50 ISO	0.60	0.50	2.20
		0.75		08NR0.75 ISO	08NL0.75 ISO	0.60	0.50	2.20
		1.0		08NR1.00 ISO	08NL1.00 ISO	0.60	0.60	2.20
		1.25		08NR1.25 ISO	08NL1.25 ISO	0.60	0.70	2.20
		1.5		08NR1.50 ISO	08NL1.50 ISO	0.60	0.70	2.20
1/4"	11	1.75		08NR1.75 ISO	08NL1.75 ISO	0.60	0.80	2.20
		0.5		11NR0.50 ISO	11NL0.50 ISO	0.60	0.60	3.20
		0.75		11NR0.75 ISO	11NL0.75 ISO	0.60	0.60	3.20
		1.0		11NR1.00 ISO	11NL1.00 ISO	0.60	0.70	3.20
		1.25		11NR1.25 ISO	11NL1.25 ISO	0.80	0.90	3.20
		1.5		11NR1.50 ISO	11NL1.50 ISO	0.80	1.00	3.20
3/8"	16	1.75		11NR1.75 ISO	11NL1.75 ISO	0.90	1.10	3.20
		2.0		11NR2.00 ISO	11NL2.00 ISO	1.00	1.30	3.20
		0.5		16NR0.50 ISO	16NL0.50 ISO	0.60	0.60	3.65
		0.75		16NR0.75 ISO	16NL0.75 ISO	0.60	0.60	3.65
		1.0		16NR1.00 ISO	16NL1.00 ISO	0.60	0.70	3.65
		1.25		16NR1.25 ISO	16NL1.25 ISO	0.80	0.90	3.65
		1.5		16NR1.50 ISO	16NL1.50 ISO	0.80	1.00	3.65
		1.75		16NR1.75 ISO	16NL1.75 ISO	0.90	1.20	3.65
1/2"	22	2.0		16NR2.00 ISO	16NL2.00 ISO	1.00	1.30	3.65
		2.5		16NR2.50 ISO	16NL2.50 ISO	1.10	1.50	3.65
		3.0		16NR3.00 ISO	16NL3.00 ISO	1.10	1.50	3.65
		3.5		22NR3.50 ISO	22NL3.50 ISO	1.60	2.30	4.76
		4.0		22NR4.00 ISO	22NL4.00 ISO	1.60	2.30	4.76
		4.5		22NR4.50 ISO	22NL4.50 ISO	1.60	2.40	4.76
5/8"	27	5.0		22NR5.00 ISO	22NL5.00 ISO	1.60	2.50	4.76
		5.5		27NR5.50 ISO	27NL5.50 ISO	1.90	2.70	6.35
		6.0		27NR6.00 ISO	27NL6.00 ISO	2.00	2.90	6.35

THREADING TOOLS

ISO标准型螺纹刀片(续) ISO Metric Full Profile (con't)

立装型 V Style

内切圆直径 Insert Size		加工螺距范围 Pitch		刀片型号 Ordering Code		刀片尺寸 Dimensions (mm)		
IC	L mm	mm	右旋螺纹 RH	左旋螺纹 LH	X	Y	T	
3/8"	16	0.5	16VNR0.50 ISO	16VNL0.50 ISO	1.10	3.00	3.65	
		0.75	16VNR0.75 ISO	16VNL0.75 ISO	1.10	3.00	3.65	
		1.0	16VNR1.00 ISO	16VNL1.00 ISO	1.10	2.90	3.65	
		1.25	16VNR1.25 ISO	16VNL1.25 ISO	1.10	2.70	3.65	
		1.5	16VNR1.50 ISO	16VNL1.50 ISO	1.10	2.60	3.65	
		1.75	16VNR1.75 ISO	16VNL1.75 ISO	1.10	2.45	3.65	
		2.0	16VNR2.00 ISO	16VNL2.00 ISO	1.10	2.30	3.65	
		2.5	16VNR2.50 ISO	16VNL2.50 ISO	1.10	2.10	3.65	
		3.0	16VNR3.00 ISO	16VNL3.00 ISO	1.10	2.00	3.65	
5/8"	27	6.0	27VNR6.00 ISO	27VNL6.00 ISO	1.00	3.30	6.35	
		8.0	27VNR8.00 ISO	27VNL8.00 ISO	1.00	4.30	8.70	
		10.0	27VNR10.0 ISO	27VNL10.0 ISO	1.00	5.20	10.0	

梳齿型 M Style

内切圆直径 Insert Size		加工螺距范围 Pitch		刀片型号 Ordering Code		刀片尺寸 Dimensions (mm)		
IC	L mm	mm	右旋螺纹 RH	左旋螺纹 LH	X	Y	T	
3/8"	16	1.0	16NR1.00 ISO3M		1.80	2.60	3.65	
		1.5	16NR1.50 ISO2M		1.60	2.40	3.65	
1/2"	22	1.5	22NR1.50 ISO3M		2.50	3.80	4.76	
		2.0	22NR2.00 ISO2M		2.10	3.10	4.76	
		2.0	22NR2.00 ISO3M		3.20	5.10	4.76	
5/8"	27	3.0	27NR3.00 ISO2M		3.00	4.60	6.35	

THREADING TOOLS

UN-60° 美制统一标准螺纹刀片 UN-60° American UN Full Profile

外螺纹 External

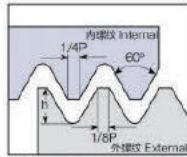

标准: ANSI B1.1:74
Defined by: ANSI B1.1:74
精度等级: 2A/2B
Tolerance class: 2A/2B

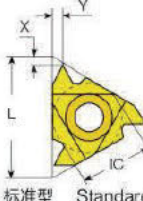

标准型 Standard

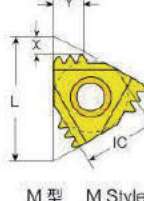

M型 M Style

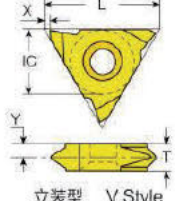

立装型 V Style

标准型 Standard

内切圆直径 Insert Size		加工螺距范围 Pitch		刀片型号 Ordering Code		刀片尺寸 Dimensions (mm)		
IC	L mm	TPI	右旋螺纹 RH	左旋螺纹 LH	X	Y	T	
1/4"	11	32	11ER32 UN	11EL32 UN	0.60	0.60	3.20	
		28	11ER28 UN	11EL28 UN	0.60	0.70	3.20	
		24	11ER24 UN	11EL24 UN	0.70	0.80	3.20	
		20	11ER20 UN	11EL20 UN	0.80	0.90	3.20	
		18	11ER18 UN	11EL18 UN	0.80	1.00	3.20	
		16	11ER16 UN	11EL16 UN	0.90	1.10	3.20	
3/8"	16	32	16ER32 UN	16EL32 UN	0.60	0.60	3.65	
		28	16ER28 UN	16EL28 UN	0.60	0.70	3.65	
		24	16ER24 UN	16EL24 UN	0.70	0.80	3.65	
		20	16ER20 UN	16EL20 UN	0.80	0.90	3.65	
		18	16ER18 UN	16EL18 UN	0.80	1.00	3.65	
		16	16ER16 UN	16EL16 UN	0.90	1.10	3.65	
		14	16ER14 UN	16EL14 UN	1.00	1.20	3.65	
		13	16ER13 UN	16EL13 UN	1.10	1.30	3.65	
		12	16ER12 UN	16EL12 UN	1.10	1.40	3.65	
		11.5	16ER11.5 UN	16EL11.5 UN	1.10	1.40	3.65	
		11	16ER11 UN	16EL11 UN	1.10	1.50	3.65	
		10	16ER10 UN	16EL10 UN	1.10	1.50	3.65	
1/2"	22	9	16ER9 UN	16EL9 UN	1.20	1.70	3.65	
		8	16ER8 UN	16EL8 UN	1.20	2.00	3.65	
		7	22ER7 UN	22EL7 UN	1.60	2.30	4.76	
		6	22ER6 UN	22EL6 UN	1.60	2.30	4.76	
5/8"	27	5	22ER5 UN	22EL5 UN	1.70	2.50	4.76	
		4.5	27ER4.5 UN	27EL4.5 UN	1.90	2.70	6.35	
		4	27ER4 UN	27EL4 UN	2.10	3.00	6.35	

THREADING TOOLS

UN-60° 美制统一标准螺纹刀片(续) UN-60° American UN Full Profile (cont)

立装型 V Style

内切圆直径 Insert Size		加工螺距范围 Pitch	刀片型号 Ordering Code		刀片尺寸 Dimensions (mm)		
IC	L mm	TPI	右旋螺纹 RH	左旋螺纹 LH	X	Y	T
3/8"	16	32	16VER32 UN	16VEL32 UN	1.10	3.00	3.65
		28	16VER28 UN	16VEL28 UN	1.10	3.00	3.65
		24	16VER24 UN	16VEL24 UN	1.10	2.90	3.65
		20	16VER20 UN	16VEL20 UN	1.10	2.70	3.65
		18	16VER18 UN	16VEL18 UN	1.10	2.60	3.65
		16	16VER16 UN	16VEL16 UN	1.10	2.50	3.65
		14	16VER14 UN	16VEL14 UN	1.10	2.40	3.65
		12	16VER12 UN	16VEL12 UN	1.10	2.20	3.65
		10	16VER10 UN	16VEL10 UN	1.10	2.10	3.65
		8	16VER8 UN	16VEL8 UN	1.10	2.00	3.65
1/2"	22	7	22VER7 UN	22VEL7 UN	1.10	2.50	4.76

梳齿型 M Style

内切圆直径 Insert Size		加工螺距范围 Pitch	刀片型号 Ordering Code		刀片尺寸 Dimensions (mm)		
IC	L mm	TPI	右旋螺纹 RH	左旋螺纹 LH	X	Y	T
3/8"	16	16	16ER16 UN2M		1.70	2.50	3.65
		16	22ER16 UN3M		2.60	4.10	4.76
1/2"	22	12	22ER12 UN2M		2.10	3.20	4.76
		12	22ER12 UN3M		3.40	5.30	4.76
5/8"	27	8	27ER8 UN2M		3.20	5.00	6.35

THREADING TOOLS

UN-60° 美制统一标准螺纹刀片 UN-60° American UN Full Profile

内螺纹 Internal

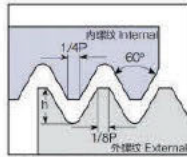

标准: ANSI B1.1:74
Defined by: ANSI B1.1:74
精度等级: 2A/2B
Tolerance class: 2A/2B

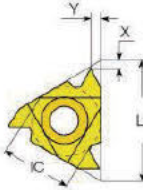

标准型 Standard

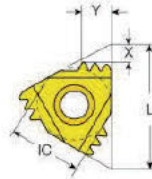

M型 M Style

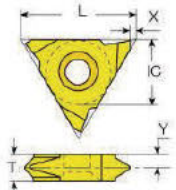

立装型 V Style

标准型 Standard

内切圆直径 Insert Size		加工螺距范围 Pitch	刀片型号 Ordering Code		刀片尺寸 Dimensions (mm)		
IC	L mm	TPI	右旋螺纹 RH	左旋螺纹 LH	X	Y	T
5/32"	06	32	06NR32 UN	06NL32 UN	0.80	0.50	1.90
		28	06NR28 UN	06NL28 UN	0.80	0.60	1.90
		24	06NR24 UN	06NL24 UN	0.70	0.60	1.90
		20	06NR20 UN	06NL20 UN	0.60	0.60	1.90
		18	06NR18 UN	06NL18 UN	0.60	0.70	1.90
3/16"	08	32	08NR32 UN	08NL32 UN	0.60	0.50	2.20
		28	08NR28 UN	08NL28 UN	0.60	0.60	2.20
		24	08NR24 UN	08NL24 UN	0.60	0.60	2.20
		20	08NR20 UN	08NL20 UN	0.60	0.70	2.20
		18	08NR18 UN	08NL18 UN	0.60	0.70	2.20
		16	08NR16 UN	08NL16 UN	0.60	0.70	2.20
1/4"	11	32	11NR32 UN	11NL32 UN	0.60	0.60	3.20
		28	11NR28 UN	11NL28 UN	0.60	0.70	3.20
		24	11NR24 UN	11NL24 UN	0.70	0.80	3.20
		20	11NR20 UN	11NL20 UN	0.80	0.90	3.20
		18	11NR18 UN	11NL18 UN	0.80	1.00	3.20
3/8"	16	32	16NR32 UN	16NL32 UN	0.60	0.60	3.65
		28	16NR28 UN	16NL28 UN	0.60	0.70	3.65
		24	16NR24 UN	16NL24 UN	0.70	0.80	3.65
		20	16NR20 UN	16NL20 UN	0.80	0.90	3.65
		18	16NR18 UN	16NL18 UN	0.80	1.00	3.65
		16	16NR16 UN	16NL16 UN	0.90	1.10	3.65
		14	16NR14 UN	16NL14 UN	1.00	1.20	3.65
		13	16NR13 UN	16NL13 UN	1.00	1.30	3.65
		12	16NR12 UN	16NL12 UN	1.10	1.40	3.65
		11	16NR11 UN	16NL11 UN	1.10	1.50	3.65
1/2"	22	10	16NR10 UN	16NL10 UN	1.10	1.50	3.65
		9	16NR9 UN	16NL9 UN	1.20	1.70	3.65
		8	16NR8 UN	16NL8 UN	1.20	2.00	3.65
		7	22NR7 UN	22NL7 UN	1.60	2.30	4.76
		6	22NR6 UN	22NL6 UN	1.60	2.30	4.76
5/8"	27	5	22NR5 UN	22NL5 UN	1.70	2.50	4.76
		4.5	27NR4.5 UN	27NL4.5 UN	1.90	2.70	6.35
		4	27NR4 UN	27NL4 UN	2.10	3.00	6.35

THREADING TOOLS

UN-60° 美制统一标准螺纹刀片(续) UN-60° American UN Full Profile (cont')

立装型 V Style

内切圆直径 Insert Size		加工螺距范围 Pitch		刀片型号 Ordering Code		刀片尺寸 Dimensions (mm)		
IC	L mm	TPI	右旋螺纹 RH	左旋螺纹 LH	X	Y	T	
5/8"	27	4	27VNR4 UN	27VNL4 UN	1.00	3.30	6.35	
		3	27VNR3 UN	27VNL3 UN	1.00	4.30	8.70	

梳齿型 M Style

内切圆直径 Insert Size		加工螺距范围 Pitch		刀片型号 Ordering Code		刀片尺寸 Dimensions (mm)		
IC	L mm	TPI	右旋螺纹 RH	左旋螺纹 LH	X	Y	T	
3/8"	16	16	16NR16 UN2M		1.70	2.40	3.65	
		16	22NR16 UN3M		2.50	4.00	4.76	
1/2"	22	12	22NR12 UN2M		2.10	3.20	4.76	
		12	22NR12 UN3M		3.30	5.20	4.76	
5/8"	27	8	27NR8 UN2M		3.00	4.80	6.35	

THREADING TOOLS

UNJ美制航空航天机械螺纹刀片 UNJ Aviation Thread

外螺纹 External



标准: MIL-S-8879C
Defined by: MIL-S-8879C
精度等级: 3A/3B
Tolerance class: 3A/3B



标准型 Standard

标准型 Standard

内切圆直径 Insert Size		加工螺距范围 Pitch	刀片型号 Ordering Code		刀片尺寸 Dimensions (mm)		
IC	L mm	TPI	右旋螺纹 RH	左旋螺纹 LH	X	Y	T
1/4"	11	28	11ER28 UNJ	11EL28 UNJ	0.70	0.70	3.20
		24	11ER24 UNJ	11EL24 UNJ	0.70	0.80	3.20
		20	11ER20 UNJ	11EL20 UNJ	0.80	0.90	3.20
		18	11ER18 UNJ	11EL18 UNJ	0.80	1.00	3.20
		16	11ER16 UNJ	11EL16 UNJ	0.90	1.10	3.20
		14	11ER14 UNJ	11EL14 UNJ	1.00	1.20	3.20
3/8"	16	28	16ER28 UNJ	16EL28 UNJ	0.70	0.70	3.65
		24	16ER24 UNJ	16EL24 UNJ	0.70	0.80	3.65
		20	16ER20 UNJ	16EL20 UNJ	0.80	0.90	3.65
		18	16ER18 UNJ	16EL18 UNJ	0.80	1.00	3.65
		16	16ER16 UNJ	16EL16 UNJ	0.90	1.10	3.65
		14	16ER14 UNJ	16EL14 UNJ	1.00	1.20	3.65
		13	16ER13 UNJ	16EL13 UNJ	1.00	1.30	3.65
		12	16ER12 UNJ	16EL12 UNJ	1.10	1.30	3.65
		11	16ER11 UNJ	16EL11 UNJ	1.20	1.50	3.65
		10	16ER10 UNJ	16EL10 UNJ	1.20	1.50	3.65
1/2"	22	7	22ER7 UNJ	22EL7 UNJ	1.70	2.30	4.76
		6	22ER6 UNJ	22EL6 UNJ	1.60	2.30	4.76
		5	22ER5 UNJ	22EL5 UNJ	1.80	2.50	4.76
5/8"	27	4.5	27ER4.5 UNJ	27EL4.5 UNJ	2.00	2.70	6.35
		4	27ER4 UNJ	27EL4 UNJ	2.20	3.00	6.35

THREADING TOOLS

UNJ美制航空航天机械螺纹刀片 UNJ Aviation Thread

内螺纹 Internal



标准: MIL-S-8879C
Defined by: MIL-S-8879C
精度等级: 3A/3B
Tolerance class: 3A/3B



标准型 Standard

标准型 Standard

内切圆直径 Insert Size		加工螺距范围 Pitch	刀片型号 Ordering Code		刀片尺寸 Dimensions (mm)		
IC	L mm	TPI	右旋螺纹 RH	左旋螺纹 LH	X	Y	T
1/4"	11	28	11NR28 UNJ	11NL28 UNJ	0.70	0.70	3.20
		24	11NR24 UNJ	11NL24 UNJ	0.70	0.80	3.20
		20	11NR20 UNJ	11NL20 UNJ	0.80	0.90	3.20
		18	11NR18 UNJ	11NL18 UNJ	0.80	1.00	3.20
		16	11NR16 UNJ	11NL16 UNJ	0.90	1.10	3.20
		14	11NR14 UNJ	11NL14 UNJ	1.00	1.20	3.20
3/8"	16	28	16NR28 UNJ	16NL28 UNJ	0.70	0.70	3.65
		24	16NR24 UNJ	16NL24 UNJ	0.70	0.80	3.65
		20	16NR20 UNJ	16NL20 UNJ	0.80	0.90	3.65
		18	16NR18 UNJ	16NL18 UNJ	0.80	1.00	3.65
		16	16NR16 UNJ	16NL16 UNJ	0.90	1.10	3.65
		14	16NR14 UNJ	16NL14 UNJ	1.00	1.20	3.65
		13	16NR13 UNJ	16NL13 UNJ	1.00	1.30	3.65
		12	16NR12 UNJ	16NL12 UNJ	1.10	1.30	3.65
		11	16NR11 UNJ	16NL11 UNJ	1.20	1.50	3.65
		10	16NR10 UNJ	16NL10 UNJ	1.20	1.50	3.65
1/2"	22	7	22NR7 UNJ	22NL7 UNJ	1.70	2.30	4.76
		6	22NR6 UNJ	22NL6 UNJ	1.60	2.30	4.76
		5	22NR5 UNJ	22NL5 UNJ	1.80	2.50	4.76
5/8"	27	4.5	27NR4.5 UNJ	27NL4.5 UNJ	2.00	2.70	6.35
		4	27NR4 UNJ	27NL4 UNJ	2.20	3.00	6.35

THREADING TOOLS

W-55° 英国惠氏螺纹刀片 W-55° Whitworth Full Profile

外螺纹 External

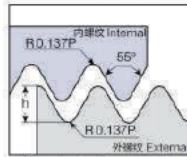

标准: B.S.84:1956, DIN 259, ISO228/1:1982
Defined by: B.S.84:1956, DIN 259, ISO228/1:1982
精度等级: Medium Class A
Tolerance class: Medium Class A

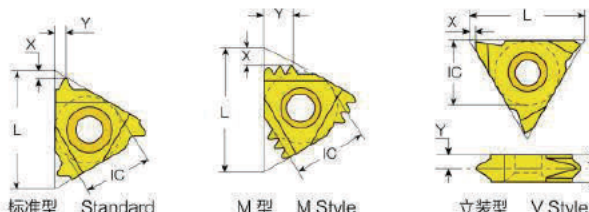

标准型 Standard M型 M Style 立装型 V Style

标准型 Standard

内切圆直径 Insert Size		加工螺距范围 Pitch		刀片型号 Ordering Code		刀片尺寸 Dimensions (mm)		
IC	L mm	TPI	右旋螺纹 RH	左旋螺纹 LH	X	Y	T	
1/4"	11	28	11ER28 W	11EL28 W	0.60	0.70	3.20	
		26	11ER26 W	11EL26 W	0.70	0.80	3.20	
		20	11ER20 W	11EL20 W	0.80	0.90	3.20	
		19	11ER19 W	11EL19 W	0.80	1.00	3.20	
		18	11ER18 W	11EL18 W	0.80	1.00	3.20	
		16	11ER16 W	11EL16 W	0.90	1.10	3.20	
3/8"	16	14	11ER14 W	11EL14 W	1.00	1.20	3.20	
		28	16ER28 W	16EL28 W	0.60	0.70	3.65	
		26	16ER26 W	16EL26 W	0.70	0.80	3.65	
		20	16ER20 W	16EL20 W	0.80	0.90	3.65	
		19	16ER19 W	16EL19 W	0.80	1.00	3.65	
		18	16ER18 W	16EL18 W	0.80	0.90	3.65	
		16	16ER16 W	16EL16 W	0.90	1.10	3.65	
		14	16ER14 W	16EL14 W	1.00	1.20	3.65	
1/2"	22	12	16ER12 W	16EL12 W	1.10	1.40	3.65	
		11	16ER11 W	16EL11 W	1.10	1.50	3.65	
		10	16ER10 W	16EL10 W	1.10	1.50	3.65	
		9	16ER9 W	16EL9 W	1.20	1.50	3.65	
		8	16ER8 W	16EL8 W	1.20	1.70	3.65	
5/8"	27	7	22ER7 W	22EL7 W	1.60	2.30	4.76	
		6	22ER6 W	22EL6 W	1.60	2.30	4.76	
		5	22ER5 W	22EL5 W	1.70	2.40	4.76	
5/8"	27	4.5	27ER4.5 W	27EL4.5 W	1.80	2.60	6.35	
		4	27ER4 W	27EL4 W	2.00	2.90	6.35	

THREADING TOOLS

W-55° 英国惠氏螺纹刀片(续) W-55° Whitworth Full Profile (con't)

立装型 V Style

内切圆直径 Insert Size		加工螺距范围 Pitch	刀片型号 Ordering Code		刀片尺寸 Dimensions (mm)		
IC	L mm	TPI	右旋螺纹 RH	左旋螺纹 LH	X	Y	T
3/8"	16	19	16VER19 W	16VEL19 W	1.10	2.70	3.65
		18	16VER18 W	16VEL18 W	1.10	2.60	3.65
		16	16VER16 W	16VEL16 W	1.10	2.60	3.65
		14	16VER14 W	16VEL14 W	1.10	2.40	3.65
		12	16VER12 W	16VEL12 W	1.10	2.40	3.65
		11	16VER11 W	16VEL11 W	1.10	2.10	3.65
5/8"	27	4	27VER4 W	27VEL4 W	1.00	3.30	6.35
		3	27VER3 W	27VEL3 W	1.00	4.30	8.70
		2.5	27VER2.5 W	27VEL2.5 W	1.00	5.20	10.0

梳齿型 M Style

内切圆直径 Insert Size		加工螺距范围 Pitch	刀片型号 Ordering Code		刀片尺寸 Dimensions (mm)		
IC	L mm	TPI	右旋螺纹 RH	左旋螺纹 LH	X	Y	T
3/8"	16	14	16ER14 W2M		1.90	2.80	3.65
1/2"	22	14	22ER14 W3M		2.90	4.60	4.76
		11	22ER11 W2M		2.30	3.50	4.76

THREADING TOOLS

W-55° 英国惠氏螺纹刀片 W-55° Whitworth Full Profile

内螺纹 Internal

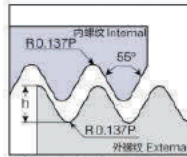

标准: B.S.84:1956, DIN 259, ISO228/1:1982
Defined by: B.S.84:1956, DIN 259, ISO228/1:1982
精度等级: Medium Class A
Tolerance class: Medium Class A

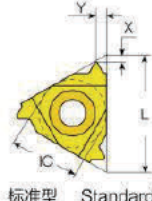

标准型 Standard

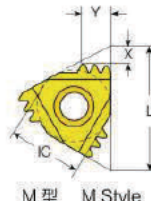

M型 M Style

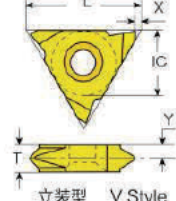

立装型 V Style

标准型 Standard

内切圆直径 Insert Size		加工螺距范围 Pitch		刀片型号 Ordering Code		刀片尺寸 Dimensions (mm)		
IC	L mm	TPI	右旋螺纹 RH	左旋螺纹 LH	X	Y	T	
5/32"	06	26	06NR26 W	06NL26 W	0.70	0.60	1.90	
		22	06NR22 W	06NL22 W	0.60	0.60	1.90	
		20	06NR20 W	06NL20 W	0.60	0.70	1.90	
		18	06NR18 W	06NL18 W	0.60	0.70	1.90	
3/16"	08	28	08NR28 W	08NL28 W	0.60	0.60	2.20	
		24	08NR24 W	08NL24 W	0.60	0.60	2.20	
		20	08NR20 W	08NL20 W	0.60	0.70	2.20	
		19	08NR19 W	08NL19 W	0.60	0.70	2.20	
		18	08NR18 W	08NL18 W	0.60	0.70	2.20	
1/4"	11	16	08NR16 W	08NL16 W	0.60	0.70	2.20	
		28	11NR28 W	11NL28 W	0.60	0.60	3.20	
		26	11NR26 W	11NL26 W	0.60	0.70	3.20	
		20	11NR20 W	11NL20 W	0.70	0.90	3.20	
		19	11NR19 W	11NL19 W	0.80	1.00	3.20	
		18	11NR18 W	11NL18 W	0.80	1.00	3.20	
		16	11NR16 W	11NL16 W	0.90	1.10	3.20	
3/8"	16	14	11NR14 W	11NL14 W	1.00	1.20	3.20	
		28	16NR28 W	16NL28 W	0.60	0.70	3.65	
		26	16NR26 W	16NL26 W	0.70	0.80	3.65	
		20	16NR20 W	16NL20 W	0.80	0.90	3.65	
		19	16NR19 W	16NL19 W	0.80	1.00	3.65	
		18	16NR18 W	16NL18 W	0.80	1.00	3.65	
		16	16NR16 W	16NL16 W	0.90	1.10	3.65	
		14	16NR14 W	16NL14 W	1.00	1.20	3.65	
		12	16NR12 W	16NL12 W	1.10	1.40	3.65	
		11	16NR11 W	16NL11 W	1.10	1.50	3.65	
1/2"	22	10	16NR10 W	16NL10 W	1.10	1.50	3.65	
		9	16NR9 W	16NL9 W	1.20	1.50	3.65	
		8	16NR8 W	16NL8 W	1.20	1.70	3.65	
		7	22NR7 W	22NL7 W	1.60	2.30	4.76	
5/8"	27	6	22NR6 W	22NL6 W	1.60	2.30	4.76	
		5	22NR5 W	22NL5 W	1.70	2.40	4.76	
		4.5	27NR4.5 W	27NL4.5 W	1.80	2.60	6.35	
		4	27NR4 W	27NL4 W	2.00	2.90	6.35	

THREADING TOOLS

W-55° 英国惠氏螺纹刀片(续) W-55° Whitworth Full Profile (con't)

立装型 V Style

内切圆直径 Insert Size		加工螺距范围 Pitch		刀片型号 Ordering Code		刀片尺寸 Dimensions (mm)		
IC	L mm	TPI	右旋螺纹 RH	左旋螺纹 LH	X	Y	T	
5/8"	27	4	27VNR4 W	27VNL4 W	1.00	3.30	6.35	
		3	27VNR3 W	27VNL3 W	1.00	4.30	8.70	
		2.5	27VNR2.5 W	27VNL2.5 W	1.00	5.20	10.0	

梳齿型 M Style

内切圆直径 Insert Size		加工螺距范围 Pitch		刀片型号 Ordering Code		刀片尺寸 Dimensions (mm)		
IC	L mm	TPI	右旋螺纹 RH	左旋螺纹 LH	X	Y	T	
3/8"	16	14	16NR14 W2M		1.90	2.80	3.65	
1/2"	22	14	22NR14 W3M		2.90	4.60	4.76	
		11	22NR11 W2M		2.30	3.50	4.76	

THREADING TOOLS

NPTF美制干密封锥管螺纹刀片 NPTF(Dry seal)

外螺纹 External

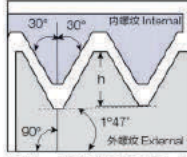

标准: ANSI B1.20.3-1976
Defined by: ANSI B1.20.3-1976
精度等级: 标准 NPTF
Tolerance class: Standard NPTF

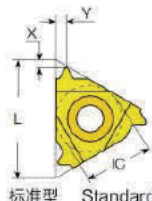

标准型 Standard

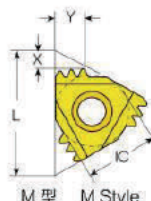

M型 M Style

标准型 Standard

内切圆直径 Insert Size		加工螺距范围 Pitch		刀片型号 Ordering Code		刀片尺寸 Dimensions (mm)		
IC	L mm	TPI	右旋螺纹 RH	左旋螺纹 LH	X	Y	T	
1/4"	11	27	11ER27 NPTF	11EL27 NPTF	0.70	0.80	3.20	
		18	11ER18 NPTF	11EL18 NPTF	0.80	1.00	3.20	
		14	11ER14 NPTF	11EL14 NPTF	0.80	1.00	3.20	
3/8"	16	27	16ER27 NPTF	16EL27 NPTF	0.70	0.80	3.65	
		18	16ER18 NPTF	16EL18 NPTF	0.80	1.00	3.65	
		14	16ER14 NPTF	16EL14 NPTF	0.90	1.20	3.65	
		11.5	16ER11.5 NPTF	16EL11.5 NPTF	1.10	1.50	3.65	
		8	16ER8 NPTF	16EL8 NPTF	1.30	1.80	3.65	

梳齿型 M Style

内切圆直径 Insert Size		加工螺距范围 Pitch		刀片型号 Ordering Code		刀片尺寸 Dimensions (mm)		
IC	L mm	TPI	右旋螺纹 RH	左旋螺纹 LH	X	Y	T	
1/2"	22	11.5	22ER11.5 NPTF2M		3.40	2.20	4.76	

THREADING TOOLS

NPTF美制干密封锥管螺纹刀片 NPTF(Dry seal)

内螺纹 Internal

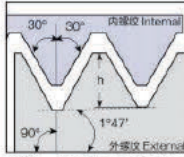

标准: ANSI B1.20.3-1976
Defined by: ANSI B1.20.3-1976
精度等级: 标准 NPTF
Tolerance class: Standard NPTF

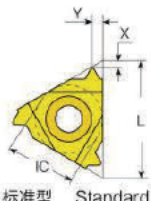

标准型 Standard

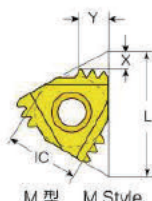

M型 M Style

标准型 Standard

内切圆直径 Insert Size		加工螺距范围 Pitch	刀片型号 Ordering Code		刀片尺寸 Dimensions (mm)		
IC	L mm	TPI	右旋螺纹 RH	左旋螺纹 LH	X	Y	T
5/32"	06	27	06NR27 NPTF	06NL27 NPTF	0.70	0.60	1.90
		18	08NR18 NPTF	08NL18 NPTF	0.60	0.60	2.20
1/4"	11	27	11NR27 NPTF	11NL27 NPTF	0.70	0.80	3.20
		18	11NR18 NPTF	11NL18 NPTF	0.80	1.00	3.20
		14	11NR14 NPTF	11NL14 NPTF	0.80	1.00	3.20
3/8"	16	27	16NR27 NPTF	16NL27 NPTF	0.70	0.80	3.65
		18	16NR18 NPTF	16NL18 NPTF	0.80	1.00	3.65
		14	16NR14 NPTF	16NL14 NPTF	0.90	1.20	3.65
		11.5	16NR11.5 NPTF	16NL11.5 NPTF	1.10	1.50	3.65
		8	16NR8 NPTF	16NL8 NPTF	1.30	1.80	3.65

梳齿型 M Style

内切圆直径 Insert Size		加工螺距范围 Pitch	刀片型号 Ordering Code		刀片尺寸 Dimensions (mm)		
IC	L mm	TPI	右旋螺纹 RH	左旋螺纹 LH	X	Y	T
1/2"	22	11.5	22NR11.5 NPTF2M		3.40	2.20	4.76
5/8"	27	11.5	27NR11.5 NPTF3M		3.50	2.20	6.35

THREADING TOOLS

NPT-60° 美国标准锥管螺纹刀片 NPT-60° National Pipe Threads

外螺纹 External

标准: USAS B2.1:1968
Defined by: USAS B2.1:1968
精度等级: 标准 NPT
Tolerance class: Standard NPT

标准型 Standard

内切圆直径 Insert Size		加工螺距范围 Pitch		刀片型号 Ordering Code		刀片尺寸 Dimensions (mm)		
IC	L mm	TPI	右旋螺纹 RH	左旋螺纹 LH	X	Y	T	
1/4"	11	27	11ER27 NPT	11EL27 NPT	0.70	0.80	3.20	
		18	11ER18 NPT	11EL18 NPT	0.80	1.00	3.20	
		14	11ER14 NPT	11EL14 NPT	0.80	1.00	3.20	
3/8"	16	27	16ER27 NPT	16EL27 NPT	0.70	0.80	3.65	
		18	16ER18 NPT	16EL18 NPT	0.80	1.00	3.65	
		14	16ER14 NPT	16EL14 NPT	0.90	1.00	3.65	
		11.5	16ER11.5 NPT	16EL11.5 NPT	1.10	1.50	3.65	
		8	16ER8 NPT	16EL8 NPT	1.20	1.80	3.65	

立装型 V Style

内切圆直径 Insert Size		加工螺距范围 Pitch		刀片型号 Ordering Code		刀片尺寸 Dimensions (mm)		
IC	L mm	TPI	右旋螺纹 RH	左旋螺纹 LH	X	Y	T	
3/8"	16	27	16VER27 NPT	16VEL27 NPT	1.10	2.90	3.65	
		18	16VER18 NPT	16VEL18 NPT	1.10	2.60	3.65	
		14	16VER14 NPT	16VEL14 NPT	1.10	2.30	3.65	
		11.5	16VER11.5 NPT	16VEL11.5 NPT	1.10	2.10	3.65	

梳齿型 M Style

内切圆直径 Insert Size		加工螺距范围 Pitch		刀片型号 Ordering Code		刀片尺寸 Dimensions (mm)		
IC	L mm	TPI	右旋螺纹 RH	左旋螺纹 LH	X	Y	T	
1/2"	22	11.5	22ER11.5 NPT2M		3.40	2.20	4.76	
5/8"	27	11.5	27ER11.5 NPT3M		3.50	5.60	6.35	
		8	27ER8 NPT2M		2.90	4.70	6.35	

THREADING TOOLS

NPT-60° 美国标准锥管螺纹刀片 NPT-60° National Pipe Threads

内螺纹 Internal

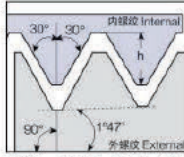

标准: USAS B2.1:1968
Defined by: USAS B2.1:1968
精度等级: 标准 NPT
Tolerance class: Standard NPT

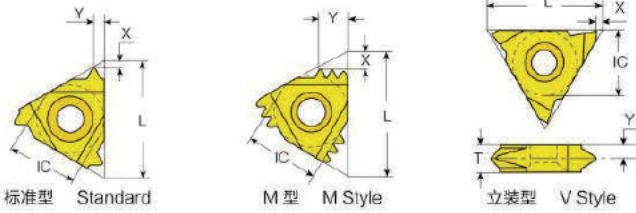

标准型 Standard M型 M Style 立装型 V Style

标准型 Standard

内切圆直径 Insert Size		加工螺距范围 Pitch		刀片型号 Ordering Code		刀片尺寸 Dimensions (mm)		
IC	L mm	TPI	右旋螺纹 RH	左旋螺纹 LH	X	Y	T	
5/32"	06	27	06NR27 NPT	06NL27 NPT	0.60	0.60	1.90	
		18	08NR18 NPT	08NL18 NPT	0.60	0.60	2.20	
3/16"	08	27	11NR27 NPT	11NL27 NPT	0.70	0.80	3.20	
		18	11NR18 NPT	11NL18 NPT	0.80	1.00	3.20	
		14	11NR14 NPT	11NL14 NPT	0.80	1.00	3.20	
1/4"	11	27	16NR27 NPT	16NL27 NPT	0.70	0.80	3.65	
		18	16NR18 NPT	16NL18 NPT	0.80	1.00	3.65	
		14	16NR14 NPT	16NL14 NPT	0.80	1.00	3.65	
		11.5	16NR11.5 NPT	16NL11.5 NPT	1.10	1.50	3.65	
		8	16NR8 NPT	16NL8 NPT	1.20	1.80	3.65	

梳齿型 M Style

内切圆直径 Insert Size		加工螺距范围 Pitch		刀片型号 Ordering Code		刀片尺寸 Dimensions (mm)		
IC	L mm	TPI	右旋螺纹 RH	左旋螺纹 LH	X	Y	T	
1/2"	22	11.5	22NR11.5 NPT2M		3.40	2.20	4.76	
5/8"	27	11.5	27NR11.5 NPT3M		3.50	5.60	6.35	
		8	27ER8 NPT2M		2.90	4.70	6.35	

THREADING TOOLS

BSPT-55° 英国标准锥管螺纹刀片 BSPT-55° British Standard Pipe Full Profile

外螺纹 External

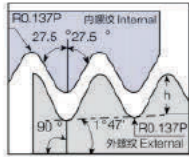

标准: B.S.21:1985
Defined by: B.S.21:1985
精度等级: 标准 BSPT
Tolerance class: Standard BSPT

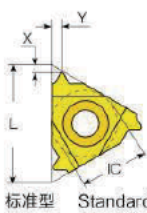

标准型 Standard

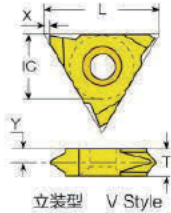

立装型 V Style

标准型 Standard

内切圆直径 Insert Size		加工螺距范围 Pitch	刀片型号 Ordering Code		刀片尺寸 Dimensions (mm)		
IC	L mm	TPI	右旋螺纹 RH	左旋螺纹 LH	X	Y	T
1/4"	11	28	11ER28 BSPT	11EL28 BSPT	0.60	0.60	3.20
		19	11ER19 BSPT	11EL19 BSPT	0.80	0.90	3.20
		14	11ER14 BSPT	11EL14 BSPT	0.90	1.00	3.20
3/8"	16	28	16ER28 BSPT	16EL28 BSPT	0.60	0.60	3.65
		19	16ER19 BSPT	16EL19 BSPT	0.80	0.90	3.65
		14	16ER14 BSPT	16EL14 BSPT	1.00	1.20	3.65
		11	16ER11 BSPT	16EL11 BSPT	1.10	1.50	3.65

立装型 V Style

内切圆直径 Insert Size		加工螺距范围 Pitch	刀片型号 Ordering Code		刀片尺寸 Dimensions (mm)		
IC	L mm	TPI	右旋螺纹 RH	左旋螺纹 LH	X	Y	T
3/8"	16	28	16VER28 BSPT	16VEL28 BSPT	1.10	3.00	3.65
		19	16VER19 BSPT	16VEL19 BSPT	1.10	2.70	3.65
		14	16VER14 BSPT	16VEL14 BSPT	1.10	2.40	3.65
		11	16VER11 BSPT	16VEL11 BSPT	1.10	2.10	3.65

THREADING TOOLS

BSPT-55° 英国标准锥管螺纹刀片 BSPT-55° British Standard Pipe Full Profile

内螺纹 Internal



标准: B.S.21:1985
Defined by: B.S.21:1985
精度等级: 标准 BSPT
Tolerance class: Standard BSPT



标准型 Standard

标准型 Standard

内切圆直径 Insert Size		加工螺距范围 Pitch		刀片型号 Ordering Code		刀片尺寸 Dimensions (mm)		
IC	L mm	TPI	右旋螺纹 RH	左旋螺纹 LH	X	Y	T	
5/32"	06	28	06NR28 BSPT	06NL28 BSPT	0.70	0.60	1.90	
		19	08NR19 BSPT	08NL19 BSPT	0.60	0.60	2.20	
3/16"	08	28	11NR28 BSPT	11NL28 BSPT	0.60	0.80	3.20	
		19	11NR19 BSPT	11NL19 BSPT	0.80	0.90	3.20	
		14	11NR14 BSPT	11NL14 BSPT	0.90	1.00	3.20	
1/4"	11	28	16NR28 BSPT	16NL28 BSPT	0.60	0.60	3.65	
		19	16NR19 BSPT	16NL19 BSPT	0.80	0.90	3.65	
		14	16NR14 BSPT	16NL14 BSPT	1.00	1.20	3.65	
		11	16NR11 BSPT	16NL11 BSPT	1.10	1.50	3.65	

THREADING TOOLS

ACME-29° 美制ACME梯形螺纹刀片 American ACME

标准型 Standard

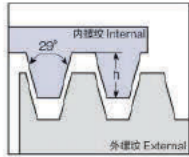

标准: ANSI B1.5:1988
Defined by: ANSI B1.5:1988
精度等级: 3G
Tolerance class:3G

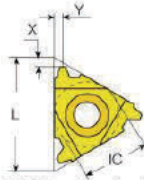

标准型 Standard
外螺纹 External

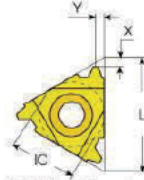

标准型 Standard
内螺纹 Internal

外螺纹 External

内切圆直径 Insert Size		加工螺距范围 Pitch	刀片型号 Ordering Code		刀片尺寸 Dimensions (mm)		
IC	L mm	TPI	右旋螺纹 RH	左旋螺纹 LH	X	Y	T
3/8"	16	16	16ER16 ACME	16EL16 ACME	1.00	1.10	3.65
		14	16ER14 ACME	16EL14 ACME	1.00	1.20	3.65
		12	16ER12 ACME	16EL12 ACME	1.10	1.20	3.65
		10	16ER10 ACME	16EL10 ACME	1.30	1.30	3.65
		8	16ER8 ACME	16EL8 ACME	1.40	1.50	3.65
1/2"	22	6	22ER6 ACME	22EL6 ACME	1.80	2.10	4.76
		5	22ER5 ACME	22EL5 ACME	2.00	2.30	4.76
5/8"	27	4	27ER4 ACME	27EL4 ACME	2.40	2.70	6.35

内螺纹 Internal

内切圆直径 Insert Size		加工螺距范围 Pitch	刀片型号 Ordering Code		刀片尺寸 Dimensions (mm)		
IC	L mm	TPI	右旋螺纹 RH	左旋螺纹 LH	X	Y	T
3/8"	16	16	16NR16 ACME	16NL16 ACME	1.00	1.10	3.65
		14	16NR14 ACME	16NL14 ACME	1.00	1.20	3.65
		12	16NR12 ACME	16NL12 ACME	1.10	1.20	3.65
		10	16NR10 ACME	16NL10 ACME	1.30	1.30	3.65
		8	16NR8 ACME	16NL8 ACME	1.40	1.50	3.65
1/2"	22	6	22NR6 ACME	22NL6 ACME	1.80	2.10	4.76
		5	22NR5 ACME	22NL5 ACME	2.00	2.30	4.76
5/8"	27	4	27NR4 ACME	27NL4 ACME	2.40	2.70	6.35

THREADING TOOLS

STACME-29° 美制ACME梯形螺纹刀片 Stub ACME

标准型 Standard

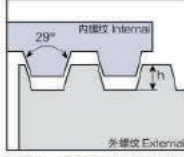

标准: ANSI B1.8:1988
Defined by: ANSI B1.8:1988
精度等级: 2G
Tolerance class: 2G

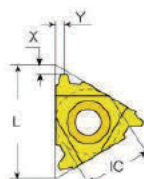

标准型 Standard
外螺纹 External

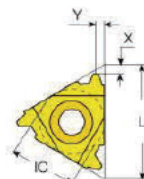

标准型 Standard
内螺纹 Internal

外螺纹 External

内切圆直径 Insert Size		加工螺距范围 Pitch		刀片型号 Ordering Code		刀片尺寸 Dimensions (mm)		
IC	L mm	TPI	右旋螺纹 RH	左旋螺纹 LH	X	Y	T	
3/8"	16	16	16ER16 STACME	16EL16 STACME	1.00	1.10	3.65	
		14	16ER14 STACME	16EL14 STACME	1.10	1.10	3.65	
		12	16ER12 STACME	16EL12 STACME	1.20	1.20	3.65	
		10	16ER10 STACME	16EL10 STACME	1.20	1.30	3.65	
		8	16ER8 STACME	16EL8 STACME	1.40	1.50	3.65	
		6	16ER6 STACME	16EL6 STACME	1.70	1.80	3.65	
1/2"	22	5	22ER5 STACME	22EL5 STACME	2.10	2.30	4.76	
5/8"	27	4	27ER4 STACME	27EL4 STACME	2.30	2.40	6.35	
		3	27ER3 STACME	27EL3 STACME	2.90	2.90	6.35	

内螺纹 Internal

内切圆直径 Insert Size		加工螺距范围 Pitch		刀片型号 Ordering Code		刀片尺寸 Dimensions (mm)		
IC	L mm	TPI	右旋螺纹 RH	左旋螺纹 LH	X	Y	T	
3/8"	16	16	16NR16 STACME	16NL16 STACME	1.00	1.10	3.65	
		14	16NR14 STACME	16NL14 STACME	1.10	1.10	3.65	
		12	16NR12 STACME	16NL12 STACME	1.20	1.20	3.65	
		10	16NR10 STACME	16NL10 STACME	1.20	1.30	3.65	
		8	16NR8 STACME	16NL8 STACME	1.40	1.50	3.65	
		6	16NR6 STACME	16NL6 STACME	1.70	1.80	3.65	
1/2"	22	5	22NR5 STACME	22NL5 STACME	2.10	2.30	4.76	
5/8"	27	4	27NR4 STACME	27NL4 STACME	2.30	2.40	6.35	
		3	27NR3 STACME	27NL3 STACME	2.90	2.90	6.35	

THREADING TOOLS

TR-30° 标准梯形螺纹刀片 Trapeze

外螺纹 External

标准: DIN 103
Defined by: DIN 103
精度等级: 7e/7H
Tolerance class: 7e/7H

标准型 Standard

内切圆直径 Insert Size		加工螺距范围 Pitch		刀片型号 Ordering Code		刀片尺寸 Dimensions (mm)		
IC	L mm	mm		右旋螺纹 RH	左旋螺纹 LH	X	Y	T
3/8"	16	1.5		16ER1.5 TR	16EL1.5 TR	1.00	1.10	3.65
		2.0		16ER2.0 TR	16EL2.0 TR	1.10	1.30	3.65
		3.0		16ER3.0 TR	16EL3.0 TR	1.30	1.50	3.65
1/2"	22	4.0		22ER4.0 TR	22EL4.0 TR	1.70	1.90	4.76
		5.0		22ER5.0 TR	22EL5.0 TR	2.10	2.50	4.76
5/8"	27	6.0		27ER6.0 TR	27EL6.0 TR	2.20	2.60	6.35
		7.0		27ER7.0 TR	27EL7.0 TR	2.30	2.70	6.35

立装型 V Style

内切圆直径 Insert Size		加工螺距范围 Pitch		刀片型号 Ordering Code		刀片尺寸 Dimensions (mm)		
IC	L mm	mm		右旋螺纹 RH	左旋螺纹 LH	X	Y	T
5/8"	27	6.0		27VER6.0 TR	27VEL6.0 TR	1.00	3.30	6.35
		7.0		27VER7.0 TR	27VEL7.0 TR	1.00	3.30	6.35
		8.0		27VER8.0 TR	27VEL8.0 TR	1.00	3.30	6.35
		9.0		27VER9.0 TR	27VEL9.0 TR	1.00	4.30	8.70
		10.0		27VER10.0 TR	27VEL10.0 TR	1.00	4.30	8.70
		12.0		27VER12.0 TR	27VEL12.0 TR	1.00	5.20	10.0

U型 U Style

内切圆直径 Insert Size		加工螺距范围 Pitch		刀片型号 Ordering Code		刀片尺寸 Dimensions (mm)		
IC	L mm	mm		右旋螺纹 RH	左旋螺纹 LH	X	Y	T
5/8"	27	8.0		27UE8.0 TR		2.60	13.7	6.35
		9.0		27UE9.0 TR		3.00	13.7	6.35

THREADING TOOLS

TR-30° 标准梯形螺纹刀片 Trapeze

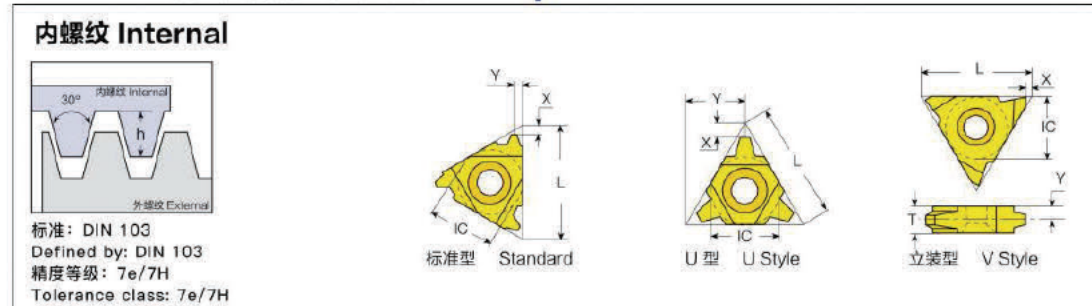

标准型 Standard

内切圆直径 Insert Size		加工螺距范围 Pitch	刀片型号 Ordering Code		刀片尺寸 Dimensions (mm)		
IC	L mm	mm	右旋螺纹 RH	左旋螺纹 LH	X	Y	T
3/8"	16	1.5	16NR1.5 TR	16NL1.5 TR	1.00	1.10	3.65
		2.0	16NR2.0 TR	16NL2.0 TR	1.10	1.30	3.65
		3.0	16NR3.0 TR	16NL3.0 TR	1.30	1.50	3.65
1/2"	22	4.0	22NR4.0 TR	22NL4.0 TR	1.70	1.90	4.76
		5.0	22NR5.0 TR	22NL5.0 TR	2.10	2.50	4.76
5/8"	27	6.0	27NR6.0 TR	27NL6.0 TR	2.20	2.60	6.35
		7.0	27NR7.0 TR	27NL7.0 TR	2.30	2.70	6.35

立装型 V Style

内切圆直径 Insert Size		加工螺距范围 Pitch	刀片型号 Ordering Code		刀片尺寸 Dimensions (mm)		
IC	L mm	mm	右旋螺纹 RH	左旋螺纹 LH	X	Y	T
5/8"	27	6.0	27VNR6.0 TR	27VNL6.0 TR	1.00	3.30	6.35
		7.0	27VNR7.0 TR	27VNL7.0 TR	1.00	3.30	6.35
		8.0	27VNR8.0 TR	27VNL8.0 TR	1.00	3.30	6.35
		9.0	27VNR9.0 TR	27VNL9.0 TR	1.00	4.30	8.70
		10.0	27VNR10.0 TR	27VNL10.0 TR	1.00	4.30	8.70
		12.0	27VNR12.0 TR	27VNL12.0 TR	1.00	5.20	10.0

U型 U Style

内切圆直径 Insert Size		加工螺距范围 Pitch	刀片型号 Ordering Code		刀片尺寸 Dimensions (mm)		
IC	L mm	mm	右旋螺纹 RH	左旋螺纹 LH	X	Y	T
5/8"	27	8.0	27UN8.0 TR		2.60	13.7	6.35
		9.0	27UN9.0 TR		3.00	13.7	6.35

THREADING TOOLS

ABUT美制锯齿形螺纹刀片 American Buttress

标准型 Standard

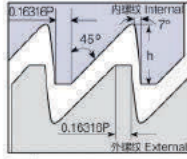

标准: ANSI B1.9.1973
Defined by: ANSI B1.9.1973
精度等级: class 2
Tolerance class: class 2

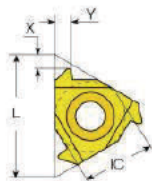

标准型 Standard
外螺纹 External

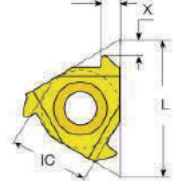

标准型 Standard
内螺纹 Internal



外螺纹 External

内切圆直径 Insert Size		加工螺距范围 Pitch		刀片型号 Ordering Code		刀片尺寸 Dimensions (mm)		
IC	L mm	TPI	右旋螺纹 RH	左旋螺纹 LH	X	Y	T	
1/4"	11	20	11ER20 ABUT	11EL20 ABUT	1.00	1.40	3.20	
		16	11ER16 ABUT	11EL16 ABUT	1.30	1.90	3.20	
3/8"	16	20	16ER20 ABUT	16EL20 ABUT	1.00	1.40	3.65	
		16	16ER16 ABUT	16EL16 ABUT	1.30	1.90	3.65	
		12	16ER12 ABUT	16EL12 ABUT	1.40	2.00	3.65	
		10	16ER10 ABUT	16EL10 ABUT	1.50	2.30	3.65	
1/2"	22	8	22ER8 ABUT	22EL8 ABUT	2.00	3.20	4.76	
		6	22ER6 ABUT	22EL6 ABUT	2.20	3.50	4.76	



内螺纹 Internal

内切圆直径 Insert Size		加工螺距范围 Pitch		刀片型号 Ordering Code		刀片尺寸 Dimensions (mm)		
IC	L mm	TPI	右旋螺纹 RH	左旋螺纹 LH	X	Y	T	
1/4"	11	20	11NR20 ABUT	11NL20 ABUT	1.00	1.40	3.20	
		16	11NR16 ABUT	11NL16 ABUT	1.30	1.90	3.20	
3/8"	16	20	16NR20 ABUT	16NL20 ABUT	1.00	1.40	3.65	
		16	16NR16 ABUT	16NL16 ABUT	1.30	1.90	3.65	
		12	16NR12 ABUT	16NL12 ABUT	1.40	2.00	3.65	
		10	16NR10 ABUT	16NL10 ABUT	1.50	2.30	3.65	
1/2"	22	8	22NR8 ABUT	22NL8 ABUT	2.00	3.20	4.76	
		6	22NR6 ABUT	22NL6 ABUT	2.20	3.50	4.76	

THREADING TOOLS

BBUT英制锯齿形螺纹刀片 British Buttress

标准型 Standard

标准: B.S.1657:1950
Defined by: B.S.1657:1950
精度等级: Medium class
Tolerance class: Medium class

标准型 外螺纹 Standard External
标准型 内螺纹 Standard Internal

外螺纹 External



内切圆直径 Insert Size		加工螺距范围 Pitch		刀片型号 Ordering Code		刀片尺寸 Dimensions (mm)		
IC	L mm	TPI	右旋螺纹 RH	左旋螺纹 LH	X	Y	T	
3/8"	16	16	16ER16 BBUT	16EL16 BBUT	1.10	1.60	3.65	
		12	16ER12 BBUT	16EL12 BBUT	1.40	2.10	3.65	
		10	16ER10 BBUT	16EL10 BBUT	1.40	2.20	3.65	
		8	16ER8 BBUT	16EL8 BBUT	1.60	2.50	3.65	
1/2"	22	8	22ER8 BBUT	22EL8 BBUT	1.60	2.50	4.76	

内螺纹 Internal



内切圆直径 Insert Size		加工螺距范围 Pitch		刀片型号 Ordering Code		刀片尺寸 Dimensions (mm)		
IC	L mm	TPI	右旋螺纹 RH	左旋螺纹 LH	X	Y	T	
3/8"	16	16	16NR16 BBUT	16NL16 BBUT	1.10	1.60	3.65	
		12	16NR12 BBUT	16NL12 BBUT	1.40	2.10	3.65	
		10	16NR10 BBUT	16NL10 BBUT	1.40	2.20	3.65	
		8	16NR8 BBUT	16NL8 BBUT	1.60	2.50	3.65	
1/2"	22	8	22NR8 BBUT	22NL8 BBUT	1.60	2.50	4.76	

THREADING TOOLS

SAGE公制锯齿形螺纹刀片 Sagengewinde

标准型 Standard

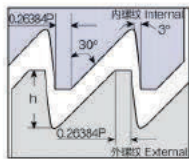

标准: DIN 513
Defined by: DIN 513
精度等级: Medium class
Tolerance class: Medium class

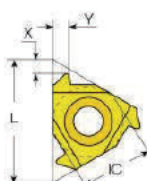

标准型 Standard
外螺纹 External

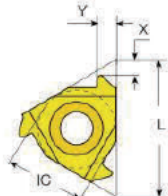

标准型 Standard
内螺纹 Internal



外螺纹 External

内切圆直径 Insert Size		加工螺距范围 Pitch		刀片型号 Ordering Code		刀片尺寸 Dimensions (mm)		
IC	L mm	mm		右旋螺纹 RH	左旋螺纹 LH	X	Y	T
3/8"	16	2.0		16ER2.0 SAGE	16EL2.0 SAGE	1.47	2.08	3.65
1/2"	22	2.0		22ER2.0 SAGE	22EL2.0 SAGE	1.47	2.08	4.76
		3.0		22ER3.0 SAGE	22EL3.0 SAGE	1.79	2.60	4.76
5/8"	27	4.0		27ER4.0 SAGE	27EL4.0 SAGE	1.93	3.20	6.35



内螺纹 Internal

内切圆直径 Insert Size		加工螺距范围 Pitch		刀片型号 Ordering Code		刀片尺寸 Dimensions (mm)		
IC	L mm	mm		右旋螺纹 RH	左旋螺纹 LH	X	Y	T
3/8"	16	2.0		16NR2.0 SAGE	16NL2.0 SAGE	1.52	2.20	3.65
1/2"	22	3.0		22NR3.0 SAGE	22NL3.0 SAGE	1.66	2.90	4.76
		4.0		27NR4.0 SAGE	27NL4.0 SAGE	2.12	3.20	6.35

THREADING TOOLS

RD消防食品机械螺纹刀片 Round DIN 405

标准型 Standard

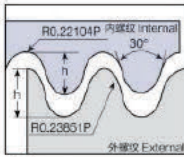

标准: DIN 405
Defined by: DIN 405
精度等级: 7h/7H
Tolerance class: 7h/7H

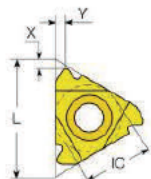

标准型 Standard
外螺纹 External

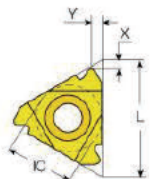

标准型 Standard
内螺纹 Internal

外螺纹 External

内切圆直径 Insert Size		加工螺距范围 Pitch		刀片型号 Ordering Code		刀片尺寸 Dimensions (mm)			
IC	L mm	TPI	右旋螺纹 RH	左旋螺纹 LH	X	Y	h min	T	
3/8"	16	10	16ER10 RD	16EL10 RD	1.10	1.20	1.27	3.65	
		8	16ER8 RD	16EL8 RD	1.30	1.40	1.59	3.65	
		6	16ER6 RD	16EL6 RD	1.50	1.70	2.12	3.65	
1/2"	22	6	22ER6 RD	22EL6 RD	1.50	1.70	2.12	4.76	
		4	22ER4 RD	22EL4 RD	1.70	2.30	3.18	4.76	
5/8"	27	4	27ER4 RD	27EL4 RD	1.70	2.30	3.18	6.35	

内螺纹 Internal

内切圆直径 Insert Size		加工螺距范围 Pitch		刀片型号 Ordering Code		刀片尺寸 Dimensions (mm)			
IC	L mm	TPI	右旋螺纹 RH	左旋螺纹 LH	X	Y	h min	T	
3/8"	16	10	16NR10 RD	16NL10 RD	1.10	1.20	1.27	3.65	
		8	16NR8 RD	16NL8 RD	1.30	1.40	1.59	3.65	
		6	16NR6 RD	16NL6 RD	1.50	1.70	2.12	3.65	
1/2"	22	6	22NR6 RD	22NL6 RD	1.50	1.70	2.12	4.76	
		4	22NR4 RD	22NL4 RD	1.70	2.30	3.18	4.76	
5/8"	27	4	27NR4 RD	27NL4 RD	1.70	2.30	3.18	6.35	

THREADING TOOLS

石油管API圆螺纹刀片 API Round Casing & Tubing

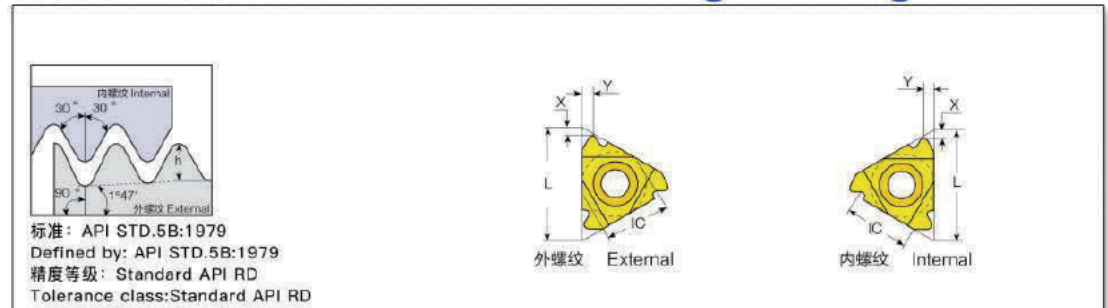

外螺纹 External

内切圆直径 Insert Size		加工螺距范围 Pitch		刀片型号 Ordering Code		刀片尺寸 Dimensions (mm)		
IC	L mm	TPI		右旋螺纹 RH		X	Y	T
3/8"	16	10		16ER10 APIRD		1.20	1.40	3.65
		8		16ER8 APIRD		1.30	1.50	3.65

内螺纹 Internal

内切圆直径 Insert Size		加工螺距范围 Pitch		刀片型号 Ordering Code		刀片尺寸 Dimensions (mm)		
IC	L mm	TPI		右旋螺纹 RH		X	Y	T
3/8"	16	10		16NR10 APIRD		1.20	1.40	3.65
		8		16NR8 APIRD		1.30	1.50	3.65

THREADING TOOLS

石油管API偏梯型螺纹刀片 API Buttress Casing

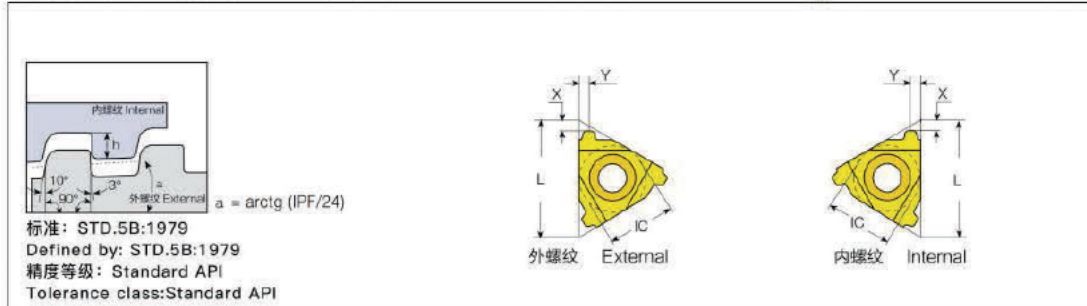

外螺纹 External

内切圆直径 Insert Size		加工螺距范围 Pitch		刀片型号 Ordering Code	刀片尺寸 Dimensions (mm)		
IC	L mm	TPI		右旋螺纹 RH	X	Y	T
1/2"	22	5		22ER5 BUT	3.10	1.90	4.76

内螺纹 Internal

内切圆直径 Insert Size		加工螺距范围 Pitch		刀片型号 Ordering Code	刀片尺寸 Dimensions (mm)		
IC	L mm	TPI		右旋螺纹 RH	X	Y	T
1/2"	22	5		22NR5 BUT	2.80	1.90	4.76

THREADING TOOLS

Pg 螺纹刀片 Pg

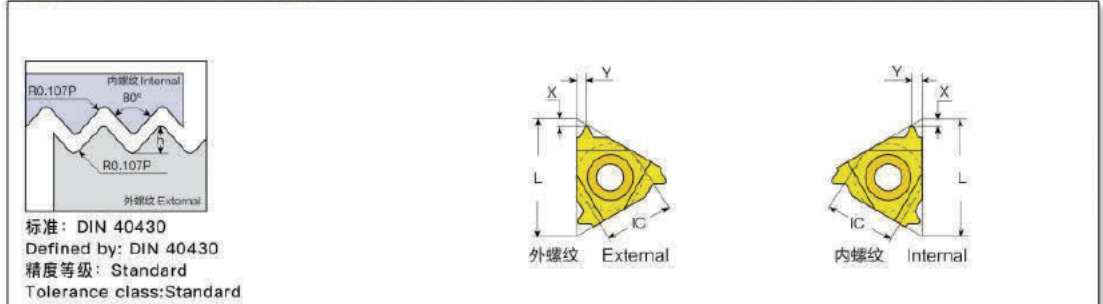

外螺纹 External

内切圆直径 Insert Size		加工螺距范围 Pitch		刀片型号 Ordering Code		刀片尺寸 Dimensions (mm)		
IC	L mm	TPI	Thread	右旋螺纹 RH	左旋螺纹 LH	X	Y	T
1/4"	11	20	Pg7	11ER20 Pg	11EL20 Pg	0.80	0.90	3.20
		18	Pg9/11/13.5/16	11ER18 Pg	11EL18 Pg	0.80	1.00	3.20
		16	Pg21/29/36/42/48	11ER16 Pg	11EL16 Pg	0.90	1.10	3.20
3/8"	16	20	Pg7	16ER20 Pg	16EL20 Pg	0.80	0.90	3.65
		18	Pg9/11/13.5/16	16ER18 Pg	16EL18 Pg	0.80	1.00	3.65
		16	Pg21/29/36/42/48	16ER16 Pg	16EL16 Pg	0.90	1.10	3.65

内螺纹 Internal

内切圆直径 Insert Size		加工螺距范围 Pitch		刀片型号 Ordering Code		刀片尺寸 Dimensions (mm)		
IC	L mm	TPI	Thread	右旋螺纹 RH	左旋螺纹 LH	X	Y	T
1/4"	11	20	Pg7	11NR20 Pg	11NL20 Pg	0.80	0.90	3.20
		18	Pg9/11/13.5/16	11NR18 Pg	11NL18 Pg	0.80	1.00	3.20
		16	Pg21/29/36/42/48	11NR16 Pg	11NL16 Pg	0.90	1.10	3.20
3/8"	16	20	Pg7	16NR20 Pg	16NL20 Pg	0.80	0.90	3.65
		18	Pg9/11/13.5/16	16NR18 Pg	16NL18 Pg	0.80	1.00	3.65
		16	Pg21/29/36/42/48	16NR16 Pg	16NL16 Pg	0.80	1.10	3.65

THREADING TOOLS

通用型立装螺纹刀片 Partial Profile V Style Inserts

60° 通用螺纹刀片 Partial Profile 60°

刀片型号 Ordering Code	加工螺距范围 Pitch	刀尖圆弧半径 corner radius
	mm	
MTTR/L 436001	1.0~1.75	R0.1
MTTR/L 436002	2.0~2.5	R0.2
MTTR/L 436003	3.0~3.5	R0.3
MTTR/L 436004	4.0~4.5	R0.4

55° 通用螺纹刀片 Partial Profile 55°

刀片型号 Ordering Code	加工螺距范围 Pitch	刀尖圆弧半径 corner radius
	mm	
MTTR/L 435501	1.0~1.75	R0.1
MTTR/L 435502	2.0~2.5	R0.2
MTTR/L 435503	3.0~3.5	R0.3
MTTR/L 435504	4.0~4.5	R0.4

旋风螺纹铣刀片 Partial Profile Thread Whirling Milling Inserts

刀片尺寸 Dimensions (mm)	刀片型号 Ordering Code
	60°通用螺纹刀片 Partial Profile 60° SV1906
	60°通用螺纹刀片 Partial Profile 60° SV1604
	60°通用螺纹刀片 Partial Profile 60° SV0903

牌号推荐一览表 List of recommended grades

MIATI TOOLS

Milling Insert And
Turning Insert Tools

工件材料 Workpiece Materials	ISO	CVD	PVD	金属陶瓷 Cermet	硬质合金 Cemented Carbide	超硬材料 Superhard Materials
P 钢 Steel	01				AS300 AT500 AC600	
	10	TC520	TP721			
	20	TC521 TC522	TP722 TP724			
	30					
	40					
M 不锈钢 Stainless Steel	01				AT500 AC600	
	10	TC620	TP621			
	20	TC622	TP622 TP624			
	30					
	40					
K 铸铁 Cast Iron	01				AS300 AT500 AC600	
	10	TC420				
	20	TC422				
	30					
S 耐热合金 钛合金 Hi-temp Alloy	01					
	10					
	20					
	30					
N 有色金属 Non-ferrous Metals	01				JTK101	
	10					
	20					
	30					
H 高硬度材料 High Hardness Materials	01			TP6000 JT3000 TP3000 JT3000	AC600	
	10					
	20					
	30					

CVD涂层介绍 Coated introduction

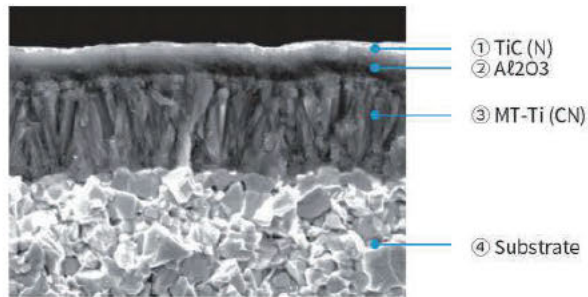

CVD涂层横截面图
Cross-sectional view of CVD coating

- ① 锡→良好的抗粘附性和表面粗糙度/TiN→ Good anti-adhesion & surface roughness
- ② 氧化铝→抗氧化/Al₂O₃→Anti-oxidation
- ③ MT CVD TiCN→细粒和柱状，具有高韧性和硬度的结构/MT CVD TiCN→Fine grain & columnar/structure with high toughness and hardness
- ④ 涂层专用基材/Exclusive substrate for coating layer

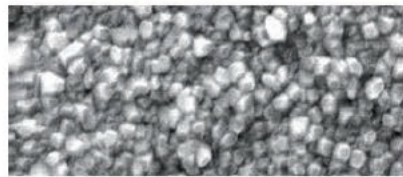

常规/Conventional

平整的表面 (更好的润滑)
Smooth surface (Better lubrication)

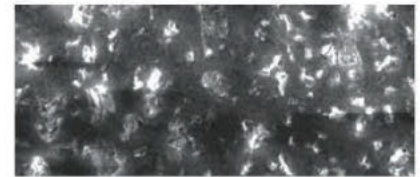

TC522

JINTE CVD系列的特点/Special Features of JINTE PVD Series

- 坚韧的基底和涂层的精细表面→抗碎裂，较少堆积边缘
- 通用等级→钢、不锈钢、铸铁、耐热超级合金的稳定刀具寿命
- Tough substrate & fine surface of coating layer→Anti-chipping, less built-up edge
- Universal grade→Stable tool life for steel, stainless, cast iron, heat resistant super alloy

特殊功能/Special Features

1. 新涂层的特殊晶体结构该技术实现了卓越的韧性。
2. 具有强大粘强度的多层涂层提供优异的耐磨性。
1. The special crystalline structure of the new coating technology achieves superior toughness.
2. A multi-layer coating with strong bonding strength provides superior wear resistance.

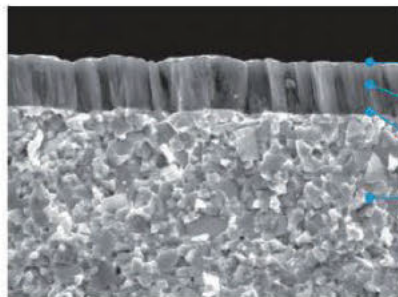

- 精细表面涂层/Fine surface coating layer
- 抗氧化涂层/ Anti-oxidation coating layer
- 涂层粘结强度高/Good bonding strength of coating layer
- 细粒坚韧基材/Fine grain tough substrate

PVD涂层横截面图

Cross-sectional view of PVD coating

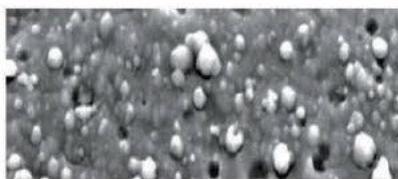

常规/Conventional

平整的表面 (更好的润滑)
Smooth surface (Better lubrication)

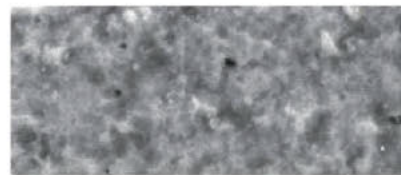

TP622

JINTE PVD系列的特点/Special Features of JINTE PVD Series

- 抗氧化涂层→适用于钢、不锈钢、铸铁、耐热超级合金
- 细粒坚韧基材和涂层的精细表面→抗碎裂，较少堆积边缘
- Coating with anti-oxidation→Suitable for steel, stainless, cast iron, heat resistant super alloy
- Fine grain tough substrate & fine surface of coating layer → Anti-chipping, less built-up edge

特殊功能/Special Features

1. PVD涂层技术具有固有的优势，如同时保持基底的韧性。因此，可以显著延长刀具寿命。
 2. PVD涂层可以在不钝化基材的情况下形成锋利的切削刃。
 3. 钛基涂层膜可提供优异的表面光洁度和高精度由于Ti膜与工件的亲合力低。
1. PVD coating technology has inherent advantages, such as maintaining the toughness of the substrate at the same time. Therefore, the tool life can be significantly extended.
 2. PVD coating can form sharp cutting edges without passivating the substrate.
 3. The Ti-based coating film can provide excellent surface finish and high precision due to the low affinity between the Ti film and the workpiece.

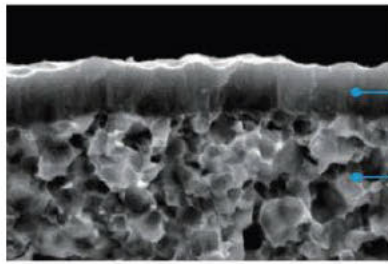

硬度高, 光滑涂层, 润滑剂层
High hardness, smooth coating,
Lubricant layer

坚韧的基材/Tough substrate

特殊功能/Special Features

JINTE金属陶瓷是一种碳氮化物型金属陶瓷通过添加TiN、TiCN粉末作为添加剂实现的微观结构。它还具有优异的韧性、抗热震性和耐磨性。
JINTE cermet is a carbonitride type cermet which has an ultra fine micro structure accomplished by adding TiN, TiCN powders as additives. It also has superior toughness, thermal shock, and wear resistance.

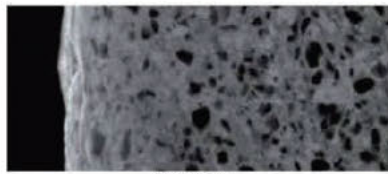

表面/Surface

TiCN基金属陶瓷的微观结构
Microstructure of TiCN-based cermets

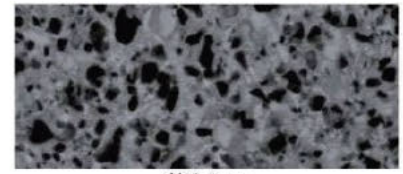

核心/Core

特殊优势/Special Advantage

以TiCN为主要成分的金属陶瓷比硬质合金更硬并且在高温下与含铁工件的亲合力较低, 因此金属陶瓷具有如下所列的特殊优势。
Cermet, using TiCN as the main component, is harder than cemented carbide and has a lower affinity with Ferrous workpiece at high temperatures, thus cermets have special advantages as listed below.

与未涂层硬质合金相比/ Compared to Un-Coated Carbide

1. 由于金属陶瓷具有优异的耐磨性和耐坑蚀性, 可以进行更高速的切割。
1. Since cermet has superior wear resistance and cratering resistance, higher speed cutting is available.
2. 由于金属陶瓷与含铁工件的亲合力低, 因此速度从低到高可以进行切割。
2. Since cermet has low affinity with ferrous workpiece, low to high speed cutting is available.
3. 与工件的低亲和性提供优异的表面光洁度。
3. Low affinity with workpiece provides excellent surface finish.
4. 可以在较高的切削速度下获得卓越的刀具寿命和切削性能速度精加工。
4. Exceptional tool life and cutting performance can be acquired at high speed finishing.

与涂层硬质合金相比/ Compared to Coated Carbide

1. 适用于轻切割 (精加工)
1. Suitable for light cutting (finishing)
2. 同时可获得更好的耐磨性和表面光洁度切削条件
2. Better wear resistance and surface finish can be acquired at the same cutting condition

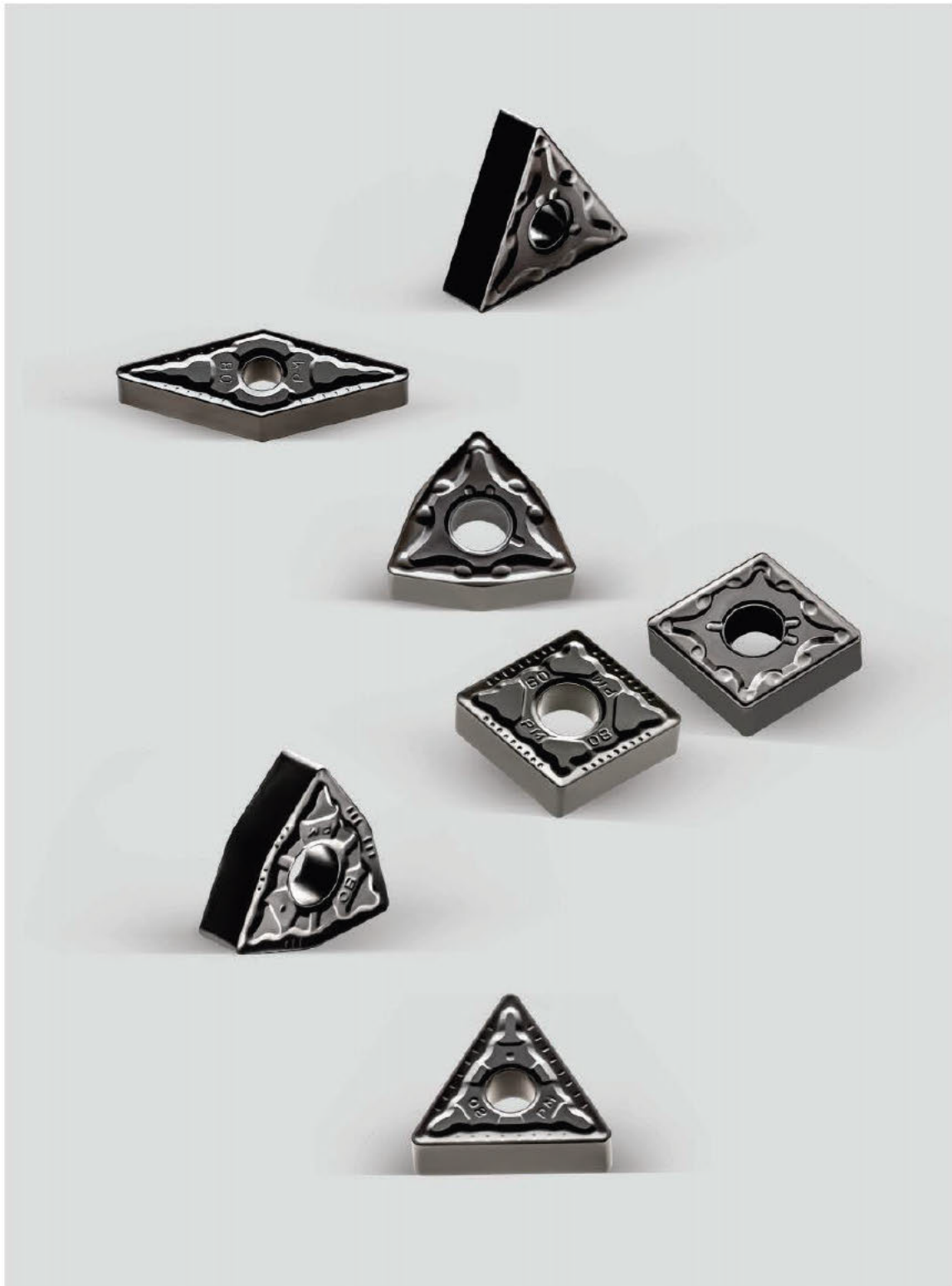

车削刀片命名规则 ISO Turning Insert Naming Rules

刀片形状/代号 The blade shape/code		
		其他 Other Z

公制 metric system							
代号 Code	有无孔 With or without hole	有无断屑槽 Presence of chip breaker groove	刀片剖面 Blade profile	代号 Code	有无孔 With or without hole	有无断屑槽 Presence of chip breaker groove	刀片剖面 Blade profile
B	有 have	无 not have		N	无 not have	无 not have	
H	有 have	单面 single face		R	无 not have	单面 single face	
C	有 have	无 not have		R	无 not have	双面 two-sided	
J	有 have	双面 two-sided		A	有 have	无 not have	
W	有 have	无 not have		M	有 have	单面 single face	
T	有 have	单面 single face		G	有 have	双面 two-sided	
Q	有 have	无 not have		X	—	—	特殊 special
U	有 have	双面 two-sided					

形状代号 Shape code

断屑槽及夹固形式 Chip breaker groove, and solid forms



主切削刃后角 After the main cutting edge Angle			
代号 Code	后角 clearance angle	代号 Code	后角 clearance angle
A		B	
C		D	
E		F	
G		N	
P		P	其他的后角 Other rear corner

公差 Tolerance			
代号 Code	刀片高度公差 (mm) Nose height tolerance (mm)	内切圆 ϕ .C公差 (mm) Indice ϕ .C tolerance (mm)	厚度公差 (mm) Thickness tolerance (mm)
A	±0.005	±0.025	±0.025
F	±0.005	±0.013	±0.013
C	±0.013	±0.025	±0.025
H	±0.013	±0.013	±0.025
E	±0.025	±0.025	±0.025
G	±0.025	±0.025	±0.13
J	±0.005	±0.05-±0.13	±0.025
K	±0.013	±0.05-±0.13	±0.025
L	±0.025	±0.05-±0.13	±0.025
M	±0.08-±0.18	±0.05-±0.13	±0.13
N	±0.08-±0.18	±0.05-±0.13	±0.025
U	±0.13-±0.38	±0.08-±0.25	±0.13

刀片高度公差 (mm) / Nose height tolerance (mm)							
内接圆 incircle	正三角形 regular triangle	正方形 square	80°菱形 80°rhombus	55°菱形 55°rhombus	35°菱形 35°rhombus	圆形 roundness	
6.35	±0.08	±0.08	±0.08	±0.11	±0.16	—	
9.525	±0.08	±0.08	±0.08	±0.11	±0.16	—	
12.7	±0.13	±0.13	±0.13	±0.15	—	—	
15.875	±0.15	±0.15	±0.15	±0.18	—	—	
19.05	±0.15	±0.15	±0.15	±0.18	—	—	
25.4	—	±0.18	—	—	—	—	

内切圆 ϕ .C公差 (mm) indice ϕ .C tolerance (mm)							
内接圆 incircle	正三角形 regular triangle	正方形 square	80°菱形 80°rhombus	55°菱形 55°rhombus	35°菱形 35°rhombus	圆形 roundness	
6.35	±0.05	±0.05	±0.05	±0.05	±0.05	—	
9.525	±0.05	±0.05	±0.05	±0.05	±0.05	±0.05	
12.7	±0.08	±0.08	±0.18	±0.08	—	±0.08	
15.875	±0.10	±0.10	±0.10	±0.10	—	±0.10	
19.05	±0.10	±0.10	±0.10	±0.10	—	±0.10	
25.4	—	±0.18	—	—	—	±0.13	

内切圆直径(mm) Inscribed circle diameter (mm)	刀片形状 The blade shape/code							
	C	D	R	S	T	V	W	K
3.97					06			
5.0			05		09			
5.56			06					
6.0			06					
6.35	06	07			11	11		
8.0			08					
9.525	09	11	09	09	16	16	06	16
10.0			10					
12.0			12					
12.7	12	15	12	12	22	22	08	
15.875	16		15	15	27			
16.0		19	16					
19.05	19		19	19	33			
20.0			20					
25.0	25	25	25					
25.4			25	25				
31.75			31					
32			32					

代号 Code	刀片厚度(mm) Blade thickness (mm)
00	0.79
T0	0.99
01	1.59
T1	1.98
02	2.38
T2	2.58
03	3.18
T3	3.97
04	4.76
T4	7.96
05	5.56
T5	5.95
06	6.35
T6	6.75
07	7.94
09	9.52
T9	9.72
11	11.11
12	12.70



切削刃长度 The length of the cutting edge 刀片厚度 Blade thickness

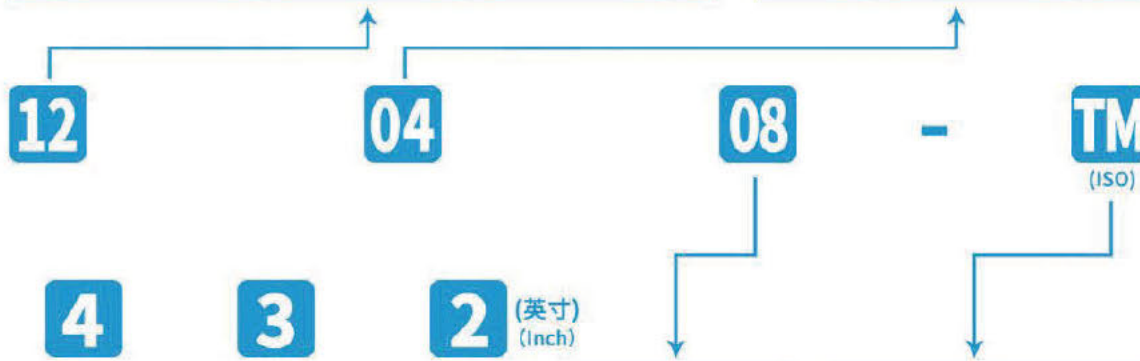

4

内切圆 Inscribed circle	
代号 Code	内切圆直径(mm) Inscribed circle diameter (mm)
2	6.35
3	9.525
4	12.7
5	15.875
6	19.05
8	25.4

3

厚度 Thickness	
代号 Code	厚度 (mm) Thickness (mm)
2	3.18
3	4.76
4	6.35
5	7.94
6	9.52

**2 (英寸)
(Inch)**

刀尖圆弧半径 Corner radius	
代号 Code	刀尖圆弧半径(mm) Corner radius (mm)
0	0.2
1	0.4
2	0.8
3	1.2
4	1.6
5	2.0
6	2.4

08

刀尖圆弧代号 The tip arc code	
代号 Code	刀尖圆弧半径(mm) corner radius (mm)
00	无圆角 No rounded corners
02	0.2
04	0.4
08	0.8
12	1.2
16	1.6
20	2.0
24	2.4
32	3.2
X	其他 Else

刀片直径尺寸
Mo(公制)
The blade diameter size
M0(metric system)

圆形刀片
circular shear blade

TM (ISO)

断屑槽代号 The code chip breaker groove	
---------------------------------------	--

TC CVD Coating

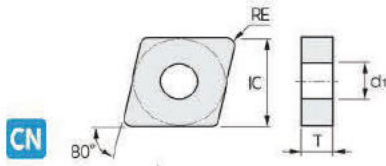

产品 Inserts Shape	型号 Type	尺寸 Dimensions(mm)				可选牌号 Grade For Choice													
		IC	T	d1	RE	TC420	TC422	TC520	TC521	TC522	TC620	TC622	TP621	TP622	TP624	TP721	TP722	TP724	
	CNMG120404	12.7	4.76	5.16	0.4			☆	★										
	CNMG120408	12.7	4.76	5.16	0.8			☆	★										
	CNMG120412	12.7	4.76	5.16	1.2			☆	★										
	CNMG160608	15.88	6.35	6.35	0.8			☆	★										
	CNMG160612	15.88	6.35	6.35	1.2			☆	★										
	CNMG190608	19.05	6.35	7.94	0.8			☆	★										
	CNMG190612	19.05	6.35	7.94	1.2			☆	★										
	CNMG190616	19.05	6.35	7.94	1.6			☆	★										
	CNMG250724	25.4	7.94	9.12	2.4			☆	★										
CNMG250924	25.4	9.525	9.12	2.4			☆	★											

★主推牌号 Primary brand number ☆可选牌号 Optional brand ○按订单生产 Production to order

产品 Inserts Shape	型号 Type	尺寸 Dimensions(mm)				可选牌号 Grade For Choice													
		IC	T	d1	RE	TC420	TC422	TC520	TC521	TC522	TC620	TC622	TP621	TP622	TP624	TP721	TP722	TP724	
	CNMA120404	12.7	4.76	5.16	0.4	★													
	CNMA120408	12.7	4.76	5.16	0.8	★													
	CNMA120412	12.7	4.76	5.16	1.2	★													
	CNMA160608	15.875	4.76	5.16	0.8	★													
	CNMA160612	15.875	4.76	5.16	1.2	★													

★主推牌号 Primary brand number ☆可选牌号 Optional brand ○按订单生产 Production to order

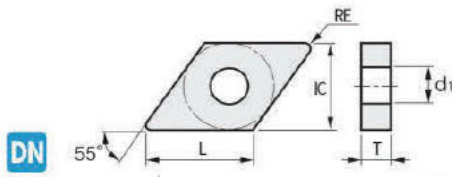

产品 Inserts Shape	型号 Type	尺寸 Dimensions(mm)					可选牌号 Grade For Choice												
		L	IC	T	d1	RE	TC420	TC422	TC520	TC521	TC522	TC620	TC622	TP621	TP622	TP624	TP721	TP722	TP724
	DNMG110404	11.6	9.52	4.76	3.81	0.4			☆	★									
	DNMG110408	11.6	9.52	4.76	3.81	0.8			☆	★									
	DNMG150404	15.5	12.7	4.76	5.16	0.4			☆	★									
	DNMG150408	15.5	12.7	4.76	5.16	0.8			☆	★									
	DNMG150412	15.5	12.7	4.76	5.16	1.2			☆	★									
	DNMG150604	15.5	12.7	4.76	5.16	0.4			☆	★									
	DNMG150608	15.5	12.7	4.76	5.16	0.8			☆	★									
	DNMG150612	15.5	12.7	4.76	5.16	1.2			☆	★									

★主推牌号 Primary brand number ☆可选牌号 Optional brand ○按订单生产 Production to order

产品 Inserts Shape	型号 Type	尺寸 Dimensions(mm)					可选牌号 Grade For Choice												
		L	IC	T	d1	RE	TC420	TC422	TC520	TC521	TC522	TC620	TC622	TP621	TP622	TP624	TP721	TP722	TP724
	DNMA150404	15.5	12.7	4.76	5.16	0.4		★											
	DNMA150408	15.5	12.7	4.76	5.16	0.8		★											
	DNMA150412	15.5	12.7	4.76	5.16	1.2		★											
	DNMA150604	15.5	12.7	4.76	5.16	0.4		★											
	DNMA150608	15.5	12.7	4.76	5.16	0.8		★											
	DNMA150612	15.5	12.7	4.76	5.16	1.2		★											

★主推牌号 Primary brand number ☆可选牌号 Optional brand ○按订单生产 Production to order

TC CVD Coating

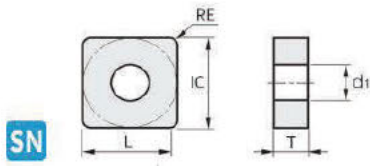

产品 Inserts Shape	型号 Type	尺寸 Dimensions(mm)					可选牌号 Grade For Choice												
		L	IC	T	d1	RE	TC420	TC422	TC520	TC521	TC522	TC620	TC622	TP621	TP622	TP624	TP721	TP722	TP724
	SNMG120404	12.7	12.7	4.76	5.16	0.4			☆	★									
	SNMG120408	12.7	12.7	4.76	5.16	0.8			☆	★									
	SNMG120412	12.7	12.7	4.76	5.16	1.2			☆	★									
	SNMG150608	15.875	15.875	6.35	6.35	0.8			☆	★									
	SNMG150612	15.875	15.875	6.35	6.35	1.2			☆	★									

★主推牌号 Primary brand number ☆可选牌号 Optional brand ○按订单生产 Production to order

产品 Inserts Shape	型号 Type	尺寸 Dimensions(mm)					可选牌号 Grade For Choice												
		L	IC	T	d1	RE	TC420	TC422	TC520	TC521	TC522	TC620	TC622	TP621	TP622	TP624	TP721	TP722	TP724
	SNMA120404	12.7	12.7	4.76	5.16	0.4	★												
	SNMA120408	12.7	12.7	4.76	5.16	0.8	★												
	SNMA120412	12.7	12.7	4.76	5.16	1.2	★												
	SNMA150608	15.875	15.875	6.35	6.35	0.8	★												
	SNMA150612	15.875	15.875	6.35	6.35	1.2	★												

★主推牌号 Primary brand number ☆可选牌号 Optional brand ○按订单生产 Production to order

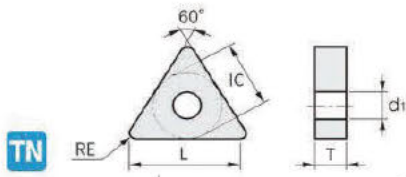

产品 Inserts Shape	型号 Type	尺寸 Dimensions(mm)					可选牌号 Grade For Choice												
		L	IC	T	d1	RE	TC420	TC422	TC520	TC521	TC522	TC620	TC622	TP621	TP622	TP624	TP721	TP722	TP724
	TNMG160404	16.5	9.52	4.76	3.81	0.4			☆	★									
	TNMG160408	16.5	9.52	4.76	3.81	0.8			☆	★									
	TNMG220404	22.0	12.7	4.76	5.16	0.4			☆	★									
	TNMG220408	22.0	12.7	4.76	5.16	0.8			☆	★									
	TNMG220412	22.0	12.7	4.76	5.16	1.2			☆	★									
	TNMG220416	22.0	12.7	4.76	5.16	1.6			☆	★									

★主推牌号 Primary brand number ☆可选牌号 Optional brand ○按订单生产 Production to order

产品 Inserts Shape	型号 Type	尺寸 Dimensions(mm)					可选牌号 Grade For Choice												
		L	IC	T	d1	RE	TC420	TC422	TC520	TC521	TC522	TC620	TC622	TP621	TP622	TP624	TP721	TP722	TP724
	TNMA220404	22.0	12.7	4.76	5.16	0.4	★												
	TNMA220408	22.0	12.7	4.76	5.16	0.8	★												
	TNMA220412	22.0	12.7	4.76	5.16	1.2	★												
	TNMA220416	22.0	12.7	4.76	5.16	1.6	★												

★主推牌号 Primary brand number ☆可选牌号 Optional brand ○按订单生产 Production to order

TC CVD Coating

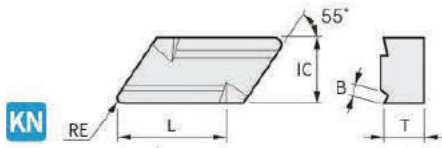

产品 Inserts Shape	型号 Type	尺寸 Dimensions(mm)					可选牌号 Grade For Choice												
		L	IC	T	d1	RE	TC420	TC422	TC520	TC521	TC522	TC620	TC622	TP621	TP622	TP624	TP721	TP722	TP724
	KNUX160405R11	16.15	1.W9.52	4.76	bm2.2	0.50			☆	★									
	KNUX160405L11	16.15	1.W9.52	4.76	bm2.2	0.50			☆	★									

★主推牌号 Primary brand number ☆可选牌号 Optional brand ○按订单生产 Production to order

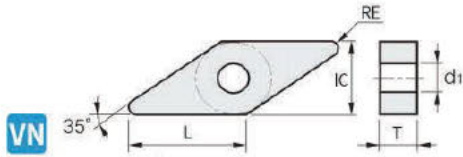

产品 Inserts Shape	型号 Type	尺寸 Dimensions(mm)					可选牌号 Grade For Choice												
		L	IC	T	d1	RE	TC420	TC422	TC520	TC521	TC522	TC620	TC622	TP621	TP622	TP624	TP721	TP722	TP724
	VNMG160404	16.6	9.52	4.76	3.81	0.4			☆	★									
	VNMG160408	16.6	9.52	4.76	3.81	0.8			☆	★									

★主推牌号 Primary brand number ☆可选牌号 Optional brand ○按订单生产 Production to order

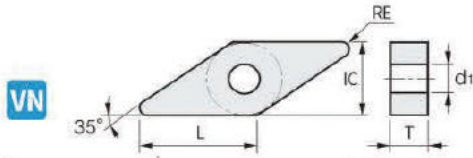

产品 Inserts Shape	型号 Type	L	IC	T	d1	RE	可选牌号 Grade For Choice													
							TC420	TC422	TC520	TC521	TC522	TC620	TC622	TP621	TP622	TP624	TP721	TP722	TP724	
	VNMA160404	16.6	9.52	4.76	3.81	0.4	★													
	VNMA160408	16.6	9.52	4.76	3.81	0.8	★													

★主推牌号Primary brand number ☆可选牌号Optional brand ○按订单生产Production to order

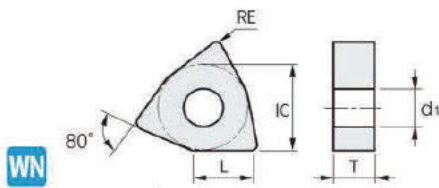

产品 Inserts Shape	型号 Type	L	IC	T	d1	RE	可选牌号 Grade For Choice													
							TC420	TC422	TC520	TC521	TC522	TC620	TC622	TP621	TP622	TP624	TP721	TP722	TP724	
	WNMG080404	8.70	12.7	4.76	5.16	0.4			☆	★										
	WNMG080408	8.70	12.7	4.76	5.16	0.8			☆	★										
	WNMG080412	8.70	12.7	4.76	5.16	1.2			☆	★										

★主推牌号Primary brand number ☆可选牌号Optional brand ○按订单生产Production to order

TC CVD Coating

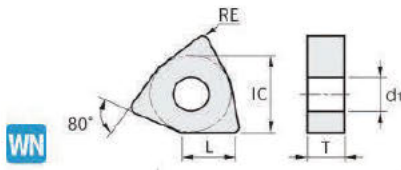

产品 Inserts Shape	型号 Type	尺寸 Dimensions(mm)					可选牌号 Grade For Choice												
		L	IC	T	d1	RE	TC420	TC422	TC520	TC521	TC522	TC620	TC622	TP621	TP622	TP624	TP721	TP722	TP724
	WNMA080404	8.7	12.7	4.76	5.16	0.4	★												
	WNMA080408	8.7	12.7	4.76	5.16	0.8	★												
	WNMA080412	8.7	12.7	4.76	5.16	1.2	★												

★主推牌号 Primary brand number ☆可选牌号 Optional brand ○按订单生产 Production to order

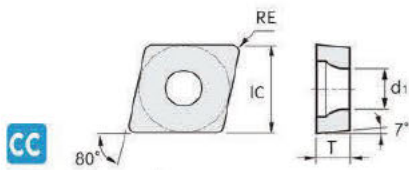

产品 Inserts Shape	型号 Type	尺寸 Dimensions(mm)					可选牌号 Grade For Choice											
		IC	T	d1	RE	TC420	TC422	TC520	TC521	TC522	TC620	TC622	TP621	TP622	TP624	TP721	TP722	TP724
	CCMT060202	6.35	2.38	2.8	0.2			☆	★									
	CCMT060204	6.35	2.38	2.8	0.4			☆	★									
	CCMT060208	6.35	2.38	2.8	0.8			☆	★									
	CCMT09T302	9.525	3.97	4.4	0.2			☆	★									
	CCMT09T304	9.525	3.97	4.4	0.4			☆	★									
	CCMT09T308	9.525	3.97	4.4	0.8			☆	★									
	CCMT120404	12.70	4.76	5.56	0.4			☆	★									
	CCMT120408	12.70	4.76	5.56	0.8			☆	★									

★主推牌号 Primary brand number ☆可选牌号 Optional brand ○按订单生产 Production to order

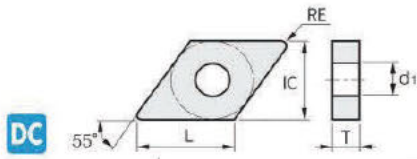

DC

产品 Inserts Shape	型号 Type	尺寸 Dimensions(mm)					可选牌号 Grade For Choice												
		L	IC	T	d1	RE	TC420	TC422	TC520	TC521	TC522	TC620	TC622	TP621	TP622	TP624	TP721	TP722	TP724
	DCMT070204	7.8	6.35	2.38	2.8	0.4			☆	★									
	DCMT070208	7.8	6.35	2.38	2.8	0.8			☆	★									
	DCMT11T304	11.6	9.52	3.97	4.4	0.4			☆	★									
	DCMT11T308	11.6	9.52	3.97	4.4	0.8			☆	★									

★主推牌号Primary brand number ☆可选牌号Optional brand ○按订单生产Production to order

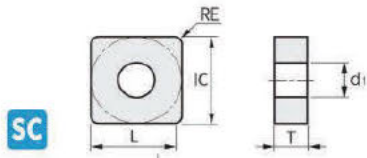

SC

产品 Inserts Shape	型号 Type	尺寸 Dimensions(mm)					可选牌号 Grade For Choice												
		L	IC	T	d1	RE	TC420	TC422	TC520	TC521	TC522	TC620	TC622	TP621	TP622	TP624	TP721	TP722	TP724
	SCMT09T304	9.525	9.25	3.97	4.4	0.4			☆	★									
	SCMT09T308	8.525	9.25	3.97	4.4	0.8			☆	★									
	SCMT120404	12.7	12.7	4.76	5.56	0.4			☆	★									
	SCMT120408	12.7	12.7	4.76	5.56	0.8			☆	★									

★主推牌号Primary brand number ☆可选牌号Optional brand ○按订单生产Production to order

TC CVD Coating

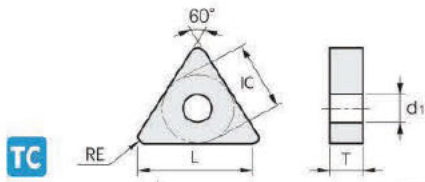

产品 Inserts Shape	型号 Type	尺寸 Dimensions(mm)					可选牌号 Grade For Choice													
		L	IC	T	d1	RE	TC420	TC422	TC520	TC521	TC522	TC620	TC622	TP621	TP622	TP624	TP721	TP722	TP724	
	TCMT090204	9.60	5.56	2.38	2.5	0.4			☆	★										
	TCMT110204	11.0	6.35	2.38	2.5	0.4			☆	★										
	TCMT16T304	16.50	9.52	3.97	4.4	0.4			☆	★										
	TCMT16T308	16.50	9.52	3.97	4.4	0.8			☆	★										

★主推牌号 Primary brand number ☆可选牌号 Optional brand ○按订单生产 Production to order

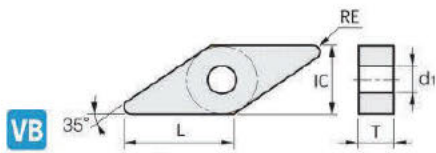

产品 Inserts Shape	型号 Type	尺寸 Dimensions(mm)					可选牌号 Grade For Choice													
		L	IC	T	d1	RE	TC420	TC422	TC520	TC521	TC522	TC620	TC622	TP621	TP622	TP624	TP721	TP722	TP724	
	VBMT110302	11.00	6.35	3.18	2.8	0.2			☆	★										
	VBMT110304	11.00	6.35	3.18	2.8	0.4			☆	★										
	VBMT160404	16.5	9.52	4.76	4.4	0.4			☆	★										
	VBMT160408	16.5	9.52	4.76	4.4	0.8			☆	★										

★主推牌号 Primary brand number ☆可选牌号 Optional brand ○按订单生产 Production to order

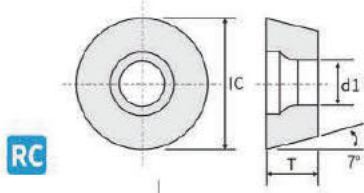

产品 Inserts Shape	型号 Type	尺寸 Dimensions(mm)				可选牌号 Grade For Choice												
		IC	T	d1	A	TC420	TC422	TC520	TC521	TC522	TC620	TC622	TP621	TP622	TP624	TP721	TP722	TP724
	RCKT10T3MO-PM	10.00	3.97	4.40	7°			☆	★									
	RCKT1204MO-PM	12.00	4.76	4.40	7°			☆	★									
	RCKT1606MO-DR	16.00	6.35	5.50	7°			☆	★									
	RCKT2006MO-PM	20.00	6.35	5.50	7°			☆	★									
	RCKT3009MO-PT	30.00	9.52	10.00	7°			☆	★									
	RCKT3209MO-R53	32.00	9.52	10.00	7°			☆	★									

★主推牌号 Primary brand number ☆可选牌号 Optional brand ○按订单生产 Production to order

TP PVD Coating

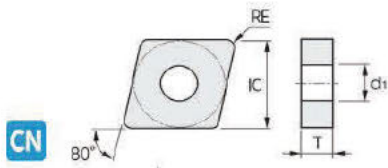

产品 Inserts Shape	型号 Type	尺寸 Dimensions(mm)				可选牌号 Grade For Choice												
		IC	T	d1	RE	TC420	TC422	TC520	TC521	TC522	TC620	TC622	TP621	TP622	TP624	TP721	TP722	TP724
	CNMG120404	12.7	4.76	5.16	0.4								☆	★	★			
	CNMG120408	12.7	4.76	5.16	0.8								☆	★	★			
	CNMG120412	12.7	4.76	5.16	1.2								☆	★	★			
	CNMG160608	15.88	6.35	6.35	0.8								☆	★	★			
	CNMG160612	15.88	6.35	6.35	1.2								☆	★	★			
	CNMG190608	19.05	6.35	7.94	0.8								☆	★	★			
	CNMG190612	19.05	6.35	7.94	1.2								☆	★	★			
	CNMG190616	19.05	6.35	7.94	1.6								☆	★	★			
	CNMG250724	25.4	7.94	9.12	2.4								☆	★	★			
CNMG250924	25.4	9.525	9.12	2.4								☆	★	★				

★主推牌号 Primary brand number ☆可选牌号 Optional brand ○按订单生产 Production to order

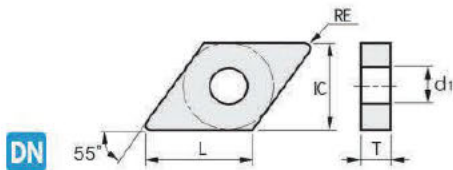

产品 Inserts Shape	型号 Type	尺寸 Dimensions(mm)					可选牌号 Grade For Choice												
		L	IC	T	d1	RE	TC420	TC422	TC520	TC521	TC522	TC620	TC622	TP621	TP622	TP624	TP721	TP722	TP724
	DNMG110404	11.6	9.52	4.76	3.81	0.4								☆	★	★			
	DNMG110408	11.6	9.52	4.76	3.81	0.8								☆	★	★			
	DNMG150404	15.5	12.7	4.76	5.16	0.4								☆	★	★			
	DNMG150408	15.5	12.7	4.76	5.16	0.8								☆	★	★			
	DNMG150412	15.5	12.7	4.76	5.16	1.2								☆	★	★			
	DNMG150604	15.5	12.7	4.76	5.16	0.4								☆	★	★			
	DNMG150608	15.5	12.7	4.76	5.16	0.8								☆	★	★			
	DNMG150612	15.5	12.7	4.76	5.16	1.2								☆	★	★			

★主推牌号 Primary brand number ☆可选牌号 Optional brand ○按订单生产 Production to order

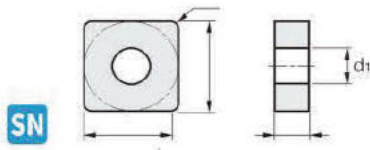

SN

产品 Inserts Shape	型号 Type	尺寸 Dimensions(mm)					可选牌号 Grade For Choice												
		L	IC	T	d1	RE	TC420	TC422	TC520	TC521	TC522	TC620	TC622	TP621	TP622	TP624	TP721	TP722	TP724
	SNMG120404	12.7	12.7	4.76	5.16	0.4								☆	★	★			
	SNMG120408	12.7	12.7	4.76	5.16	0.8								☆	★	★			
	SNMG120412	12.7	12.7	4.76	5.16	1.2								☆	★	★			
	SNMG150608	15.875	15.875	6.35	6.35	0.8								☆	★	★			
	SNMG150612	15.875	15.875	6.35	6.35	1.2								☆	★	★			

★主推牌号 Primary brand number ☆可选牌号 Optional brand ○按订单生产 Production to order

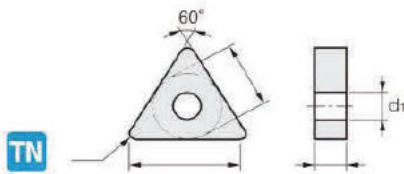

TN

产品 Inserts Shape	型号 Type	尺寸 Dimensions(mm)					可选牌号 Grade For Choice												
		L	IC	T	d1	RE	TC420	TC422	TC520	TC521	TC522	TC620	TC622	TP621	TP622	TP624	TP721	TP722	TP724
	TNMG160404	16.5	9.52	4.76	3.81	0.4								☆	★	★			
	TNMG160408	16.5	9.52	4.76	3.81	0.8								☆	★	★			
	TNMG220404	22.0	12.7	4.76	5.16	0.4								☆	★	★			
	TNMG220408	22.0	12.7	4.76	5.16	0.8								☆	★	★			
	TNMG220412	22.0	12.7	4.76	5.16	1.2								☆	★	★			
	TNMG220416	22.0	12.7	4.76	5.16	1.6								☆	★	★			

★主推牌号 Primary brand number ☆可选牌号 Optional brand ○按订单生产 Production to order

TP PVD Coating

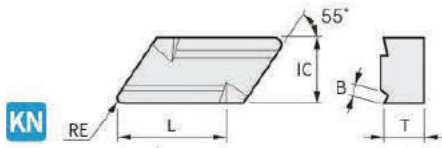

产品 Inserts Shape	型号 Type	尺寸 Dimensions(mm)					可选牌号 Grade For Choice												
		L	IC	T	d1	RE	TC420	TC422	TC520	TC521	TC522	TC620	TC622	TP621	TP622	TP624	TP721	TP722	TP724
	KNUX160405R11	16.15	1.W9.52	4.76	bm2.2	0.50									★	★			
	KNUX160405L11	16.15	1.W9.52	4.76	bm2.2	0.50									★	★			

★主推牌号 Primary brand number ☆可选牌号 Optional brand ○按订单生产 Production to order

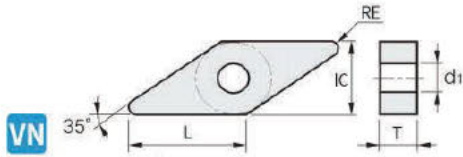

产品 Inserts Shape	型号 Type	尺寸 Dimensions(mm)					可选牌号 Grade For Choice												
		L	IC	T	d1	RE	TC420	TC422	TC520	TC521	TC522	TC620	TC622	TP621	TP622	TP624	TP721	TP722	TP724
	VNMG160404	16.6	9.52	4.76	3.81	0.4								☆	★	★			
	VNMG160408	16.6	9.52	4.76	3.81	0.8								☆	★	★			

★主推牌号 Primary brand number ☆可选牌号 Optional brand ○按订单生产 Production to order

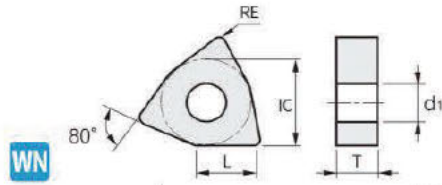

产品 Inserts Shape	型号 Type	尺寸 Dimensions(mm)					可选牌号 Grade For Choice												
		L	IC	T	d1	RE	TC420	TC422	TC520	TC521	TC522	TC620	TC622	TP621	TP622	TP624	TP721	TP722	TP724
	WNMG080404	8.70	12.7	4.76	5.16	0.4								☆	★	★			
	WNMG080408	8.70	12.7	4.76	5.16	0.8								☆	★	★			
	WNMG080412	8.70	12.7	4.76	5.16	1.2								☆	★	★			

★主推牌号Primary brand number ☆可选牌号Optional brand ○按订单生产Production to order

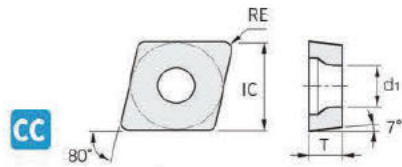

产品 Inserts Shape	型号 Type	尺寸 Dimensions(mm)					可选牌号 Grade For Choice											
		IC	T	d1	RE	TC420	TC422	TC520	TC521	TC522	TC620	TC622	TP621	TP622	TP624	TP721	TP722	TP724
	CCMT060202	6.35	2.38	2.8	0.2								☆	★	★			
	CCMT060204	6.35	2.38	2.8	0.4								☆	★	★			
	CCMT060208	6.35	2.38	2.8	0.8								☆	★	★			
	CCMT09T302	9.525	3.97	4.4	0.2								☆	★	★			
	CCMT09T304	9.525	3.97	4.4	0.4								☆	★	★			
	CCMT09T308	9.525	3.97	4.4	0.8								☆	★	★			
	CCMT120404	12.70	4.76	5.56	0.4								☆	★	★			
	CCMT120408	12.70	4.76	5.56	0.8								☆	★	★			

★主推牌号Primary brand number ☆可选牌号Optional brand ○按订单生产Production to order

TP PVD Coating

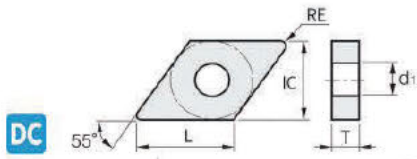

产品 Inserts Shape	型号 Type	尺寸 Dimensions(mm)					可选牌号 Grade For Choice												
		L	IC	T	d1	RE	TC420	TC422	TC520	TC521	TC522	TC620	TC622	TP621	TP622	TP624	TP721	TP722	TP724
	DCMT070204	7.8	6.35	2.38	2.8	0.4								☆	★	★			
	DCMT070208	7.8	6.35	2.38	2.8	0.8								☆	★	★			
	DCMT11T304	11.6	9.52	3.97	4.4	0.4								☆	★	★			
	DCMT11T308	11.6	9.52	3.97	4.4	0.8								☆	★	★			

★主推牌号Primary brand number ☆可选牌号Optional brand ○按订单生产Production to order

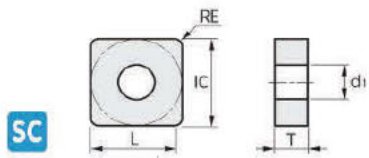

产品 Inserts Shape	型号 Type	尺寸 Dimensions(mm)					可选牌号 Grade For Choice												
		L	IC	T	d1	RE	TC420	TC422	TC520	TC521	TC522	TC620	TC622	TP621	TP622	TP624	TP721	TP722	TP724
	SCMT09T304	9.525	9.25	3.97	4.4	0.4								☆	★	★			
	SCMT09T308	8.525	9.25	3.97	4.4	0.8								☆	★	★			
	SCMT120404	12.7	12.7	4.76	5.56	0.4								☆	★	★			
	SCMT120408	12.7	12.7	4.76	5.56	0.8								☆	★	★			

★主推牌号Primary brand number ☆可选牌号Optional brand ○按订单生产Production to order

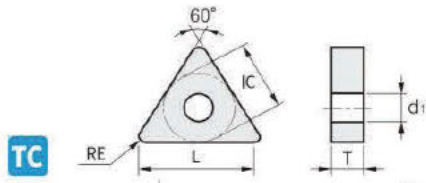

尺寸 Dimensions(mm)

可选牌号 Grade For Choice

产品 Inserts Shape	型号 Type	L	IC	T	d1	RE	可选牌号 Grade For Choice													
							TC420	TC422	TC520	TC521	TC522	TC620	TC622	TP621	TP622	TP624	TP721	TP722	TP724	
	TCMT090204	9.60	5.56	2.38	2.5	0.4										☆	★	★		
	TCMT110204	11.0	6.35	2.38	2.5	0.4										☆	★	★		
	TCMT16T304	16.50	9.52	3.97	4.4	0.4										☆	★	★		
	TCMT16T308	16.50	9.52	3.97	4.4	0.8										☆	★	★		

★主推牌号Primary brand number ☆可选牌号Optional brand ○按订单生产Production to order

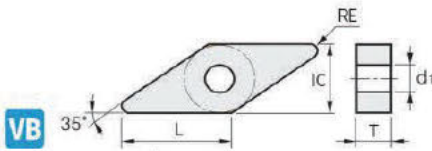

尺寸 Dimensions(mm)

可选牌号 Grade For Choice

产品 Inserts Shape	型号 Type	L	IC	T	d1	RE	可选牌号 Grade For Choice													
							TC420	TC422	TC520	TC521	TC522	TC620	TC622	TP621	TP622	TP624	TP721	TP722	TP724	
	VBMT110302	11.00	6.35	3.18	2.8	0.2										☆	★	★		
	VBMT110304	11.00	6.35	3.18	2.8	0.4										☆	★	★		
	VBMT160404	16.5	9.52	4.76	4.4	0.4										☆	★	★		
	VBMT160408	16.5	9.52	4.76	4.4	0.8										☆	★	★		

★主推牌号Primary brand number ☆可选牌号Optional brand ○按订单生产Production to order

TP PVD Coating

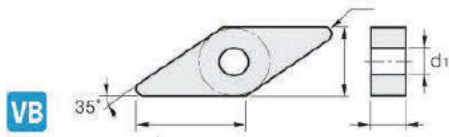

产品 Inserts Shape	型号 Type	尺寸 Dimensions(mm)					可选牌号 Grade For Choice												
		L	IC	T	d1	RE	TC420	TC422	TC520	TC521	TC522	TC620	TC622	TP621	TP622	TP624	TP721	TP722	TP724
	VCMT110302	11.00	6.35	3.18	2.8	0.2								☆	★	★			
	VCMT110304	11.00	6.35	3.18	2.8	0.4								☆	★	★			

★主推牌号Primary brand number ☆可选牌号Optional brand ○按订单生产Production to order

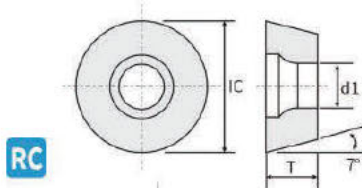

产品 Inserts Shape	型号 Type	尺寸 Dimensions(mm)				可选牌号 Grade For Choice													
		IC	T	d1	A	TC420	TC422	TC520	TC521	TC522	TC620	TC622	TP621	TP622	TP624	TP721	TP722	TP724	
	RCKT10T3MO-PM	10.00	3.97	4.40	7°									☆	★	★			
	RCKT1204MO-PM	12.00	4.76	4.40	7°									☆	★	★			
	RCKT1606MO-DR	16.00	6.35	5.50	7°									☆	★	★			
	RCKT2006MO-PM	20.00	6.35	5.50	7°									☆	★	★			
	RCKT3009MO-PT	30.00	9.52	10.00	7°									☆	★	★			
	RCKT3209MO-R63	32.00	9.52	10.00	7°									☆	★	★			

★主推牌号Primary brand number ☆可选牌号Optional brand ○按订单生产Production to order

D 钻削刀片 Drilling Insert



D 浅孔钻 Shallow hole drill

MIATI TOOLS

Milling Insert And
Turning Insert Tools

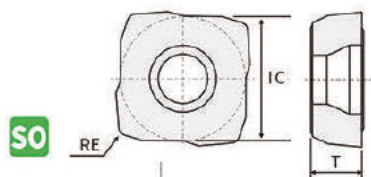

尺寸 Dimensions(mm)

可选牌号 GradeFor Choice

产品 Inserts Shape	型号 Type	IC	T	RE	可选牌号 GradeFor Choice		
					TP621	TP622	TP624
	880-030305H-C-GM	5.7	2.6	0.5		★	
	880-0303W05H-P-GM	6	2.6	0.5		★	
	880-040305H-C-GM	6.8	2.8	0.5		★	
	880-0403W05H-P-GM	7.4	2.8	0.5		★	
	880-050305H-C-GM	8.4	3	0.5		★	
	880-0503W05H-P-GM	8.9	3	0.5		★	
	880-060406H-C-GM	10.2	3.5	0.6		★	
	880-0604W06H-P-GM	10.65	3.5	0.6		★	

★主推牌号Primary brand number ☆可选牌号Optional brand ○按订单生产Production to order

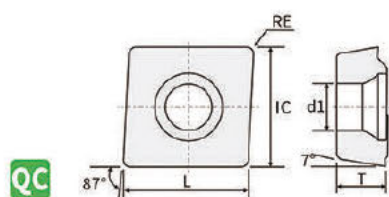

尺寸 Dimensions(mm)

可选牌号 GradeFor Choice

产品 Inserts Shape	型号 Type	L	IC	T	d1	RE	可选牌号 GradeFor Choice		
							TP621	TP622	TP624
	QCMT050204-CM	0.197	0.213	0.038	0.091	0.016		★	
	QCMT060204-CM	0.236	0.252	0.094	0.098	0.016		★	
	QCMT070304-CM	0.276	0.291	0.125	0.110	0.016		★	
	QCMT080304-CM	0.315	0.331	0.125	0.134	0.016		★	
	QCMT10T304-CM	0.394	0.409	0.156	0.157	0.016		★	

★主推牌号Primary brand number ☆可选牌号Optional brand ○按订单生产Production to order

D 浅孔钻 Shallow hole drill

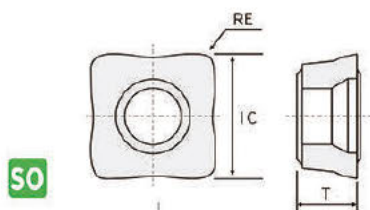

SO

尺寸 Dimensions(mm)

可选牌号 GradeForChoice

产品 Inserts Shape	型号 Type	IC	T	RE	可选牌号 GradeForChoice		
					TP621	TP622	TP624
	SOMT050204-DP	4.9	2.38	0.4	★		
	SOMT060204-DP	5.7	2.38	0.4	★		
	SOMT070306-DP	6.8	2.80	0.6	★		
	SOMT08T306-DP	7.9	3.97	0.6	★		
	SOMT09T308-DP	9.2	3.97	0.8	★		
	SOMT11T308-DP	11.0	3.97	0.8	★		

★主推牌号 Primary brand number ☆可选牌号 Optional brand ○按订单生产 Production to order

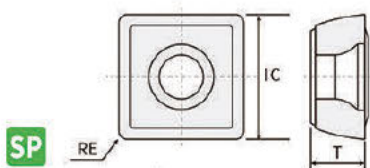

SP

尺寸 Dimensions(mm)

可选牌号 GradeForChoice

产品 Inserts Shape	型号 Type	IC	T	RE	可选牌号 GradeForChoice		
					TP621	TP622	TP624
	SPMG050204-DG	5.00	2.38	0.40		★	
	SPMG060204-DG	6.00	2.38	0.40		★	
	SPMG07T308-DG	7.94	3.97	0.80		★	
	SPMG090408-DG	9.80	4.30	0.80		★	
	SPMG110408-DG	11.50	4.80	0.80		★	
	SPMG140512-DG	14.30	5.20	1.20		★	

★主推牌号 Primary brand number ☆可选牌号 Optional brand ○按订单生产 Production to order

D 浅孔钻 Shallow hole drill

MIATI TOOLS

Milling Insert And
Turning Insert Tools

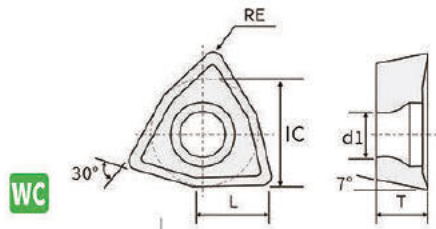

WC

尺寸 Dimensions(mm)

可选牌号 Grade For Choice

产品 Inserts Shape	型号 Type	L	T	RE	可选牌号 Grade For Choice		
					TP621	TP622	TP624
	WCMX030208R-FN	3.00	2.38	0.40			★
	WCMX040208R-FN	4.00	2.38	0.80			★
	WCMX050308R-FN	5.00	3.18	0.80			★
	WCMX06T308R-FN	6.00	3.97	0.80			★
	WCMX080412R-FN	7.00	4.76	1.20			★

★主牌号 Primary brand number ☆可选牌号 Optional brand ○按订单生产 Production to order

D深孔钻 Deep hole drill

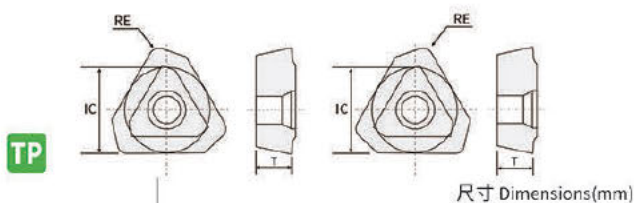

尺寸 Dimensions(mm)

可选牌号 GradeForChoice

产品 Inserts Shape	型号 Type	IC	T	RE	可选牌号 GradeForChoice		
					TP621	TP622	TP624
	TPMX1403RB	8.45	3.50	0.40	★	★	
	TPMX1403RG	8.45	3.50	0.40	★	★	
	TPMX1704RB	10.30	4.00	0.80	★	★	
	TPMX1704RG	10.30	4.00	0.80	★	★	
	TPMX2405RB	14.20	5.50	0.40	★	★	
	TPMX2405RG	14.20	5.50	0.40	★	★	
	TPMX2807RB	17.00	7.50	0.80	★	★	
	TPMX2807RG	17.00	7.50	0.80	★	★	

★主推牌号 Primary brand number ☆可选牌号 Optional brand ○按订单生产 Production to order

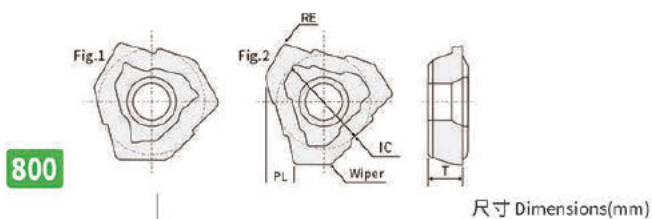

尺寸 Dimensions(mm)

可选牌号 GradeForChoice

产品 Inserts Shape	型号 Type	直径范围 Diameter range	Di	T	Eh1	RE	Fig	可选牌号 GradeForChoice		
								TP621	TP622	TP624
	TOGT 070304-DT	14.00-15.99	7.69	2.30	1.95	0.40	1	★	★	
	TOGT 080305-DT	16.00-18.00	8.55	2.80	2.20	0.50	1	★	★	
	TOGT 090305-DT	18.01-20.00	8.32	3.00	3.00	0.50	2	★	★	
	TOGT 100305-DT	20.01-21.99/21.00-21.99	9.23	3.30	3.20	0.50	2	★	★	
	TOGT 110405-DT	22.00-25.00	10.40	3.80	3.40	0.50	2	★	★	
	TOGT 120405-DT	25.01-28.00	11.59	4.30	3.60	0.50	2	★	★	

★主推牌号 Primary brand number ☆可选牌号 Optional brand ○按订单生产 Production to order

D 深孔钻 Deep hole drill

MIATI TOOLS

Milling Insert And
Turning Insert Tools

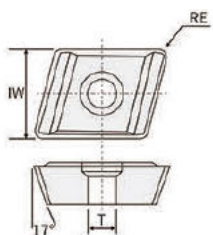

800

尺寸 Dimensions(mm)

可选牌号 GradeForChoice

产品 Inserts Shape	型号 Type	直径范围 Diameter range	L	IW	T	RE	TP621	TP622	TP624
							★	★	
	800-050308 M-C-G	25.00-28.70	9.87	5.56	3.18	0.8	★	★	
	800-06T308 M-C-G	28.71-33.99	9.87	6.35	3.97	0.8	★	★	
	800-08T308 M-C-G	34.00-43.00	9.87	7.94	3.97	0.8	★	★	
	800-10T308 M-C-G	43.01-47.00	9.87	9.53	3.97	0.8	★	★	
	800-12T308 M-C-G	47.01-49.99	9.87	12.70	3.97	0.8	★	★	

★主推牌号 Primary brand number ☆可选牌号 Optional brand ○按订单生产 Production to order

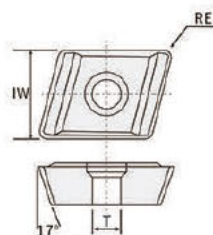

800

尺寸 Dimensions(mm)

可选牌号 GradeForChoice

产品 Inserts Shape	型号 Type	直径范围 Diameter range	L	IW	T	RE	TP621	TP622	TP624
							★	★	
	800-050308 M-C-L	25.00-28.70	9.87	5.56	3.18	0.8	★	★	
	800-06T308 M-C-L	28.71-33.99	9.87	6.35	3.97	0.8	★	★	
	800-08T308 M-C-L	34.00-43.00	9.87	7.94	3.97	0.8	★	★	
	800-10T308 M-C-L	43.01-47.00	9.87	9.53	3.97	0.8	★	★	
	800-12T308 M-C-L	47.01-49.99	9.87	12.70	3.97	0.8	★	★	

★主推牌号 Primary brand number ☆可选牌号 Optional brand ○按订单生产 Production to order

D 深孔钻 Deep hole drill

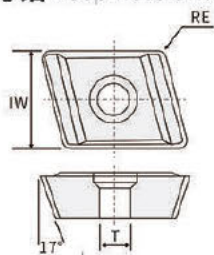

800

产品 Inserts Shape	型号 Type	直径范围 Diameter range	尺寸 Dimensions(mm)				可选牌号 Grade For Choice		
			L	IW	T	RE	TP621	TP622	TP624
	800-050308 M-I-G	25.00-28.70	9.87	5.56	3.18	0.8	★	★	
	800-06T308 M-I-G	28.71-33.99	9.87	6.35	3.97	0.8	★	★	
	800-08T308 M-I-G	34.00-43.00	9.87	7.94	3.97	0.8	★	★	
	800-12T308 M-I-G	47.01-49.99	9.87	12.70	3.97	0.8	★	★	

★主推牌号 Primary brand number ☆可选牌号 Optional brand ○按订单生产 Production to order

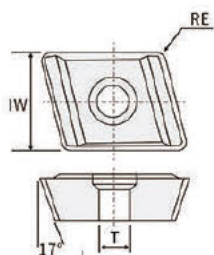

800

产品 Inserts Shape	型号 Type	直径范围 Diameter range	尺寸 Dimensions(mm)				可选牌号 Grade For Choice		
			L	IW	T	RE	TP621	TP622	TP624
	800-050308 M-I-L	25.00-28.70	9.87	5.56	3.18	0.8	★	★	
	800-06T308 M-I-L	28.71-33.99	9.87	6.35	3.97	0.8	★	★	
	800-08T308 M-I-L	34.00-43.00	9.87	7.94	3.97	0.8	★	★	
	800-12T308 M-I-L	47.01-49.99	9.87	12.70	3.97	0.8	★	★	

★主推牌号 Primary brand number ☆可选牌号 Optional brand ○按订单生产 Production to order

D 深孔钻 Deep hole drill

MIATI TOOLS

Milling Insert And
Turning Insert Tools

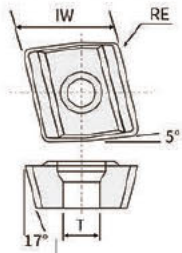

800

尺寸 Dimensions(mm)

可选牌号 GradeForChoice

产品 Inserts Shape	型号 Type	直径范围 Diameter range	L	IW	T	RE	可选牌号 GradeForChoice		
							TP621	TP622	TP624
	800-060308 H-P-G	25.00-31.00	6.50	8.00	3.18	0.8	★	★	
	800-060308 H-P-L	25.00-31.00	6.50	8.00	3.18	0.8	★	★	
	800-08T308 H-P-G	31.01-34.99	8.50	9.00	3.97	0.8	★	★	
	800-08T308 H-P-L	35.00-54.99	8.50	9.00	3.97	0.8	★	★	
	800-09T308 H-P-G	25.00-31.00	9.68	9.00	3.97	0.8	★	★	
	800-09T308 H-P-L	31.01-38.99	9.68	9.00	3.97	0.8	★	★	
	800-11T308 H-P-G	39.00-49.99	12.75	9.00	3.97	0.8	★	★	
	800-11T308 H-P-L	50.00-65.00	12.75	9.00	3.97	0.8	★	★	

★主推牌号 Primary brand number ☆可选牌号 Optional brand ○按订单生产 Production to order

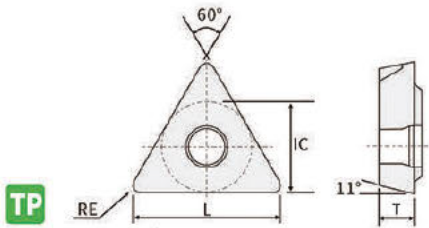

TP

尺寸 Dimensions(mm)

可选牌号 GradeForChoice

产品 Inserts Shape	型号 Type	L	IC	IW	T	RE	可选牌号 GradeForChoice		
							TP621	TP622	TP624
	TPMT16T312R-22	16.5	9.525	-	3.97	1.2	★	★	
	TPMT16T312R-23	16.5	9.525	-	3.97	1.2	★	★	
	TPMT220612R-22	22.0	12.7	-	6.35	1.2	★	★	
	TPMT220612R-23	22.0	12.7	-	6.35	1.2	★	★	

★主推牌号 Primary brand number ☆可选牌号 Optional brand ○按订单生产 Production to order

D 深孔钻 Deep hole drill

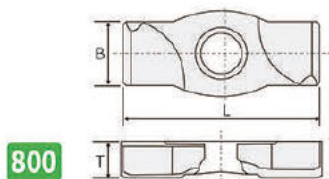

800

产品 Inserts Shape	型号 Type	直径范围 Diameter range	尺寸 Dimensions(mm)			可选牌号 Grade For Choice		
			L	B	T	TP621	TP622	TP624
	800-06A	25.00-31.00	18	6	3.0	★	★	
	800-07A	31.01-39.60	20	7	3.5	★	★	
	800-08A	39.61-47.00	25	8	4.5	★	★	
	800-10A	47.01-54.99	30	10	4.5	★	★	
	800-12A	55.00-65.00	35	12	5.5	★	★	

★主推牌号 Primary brand number ☆可选牌号 Optional brand ○按订单生产 Production to order

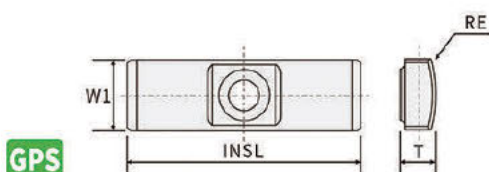

GPS

产品 Inserts Shape	型号 Type	直径范围 Diameter range	尺寸 Dimensions(mm)				可选牌号 Grade For Choice		
			IN	W1	T	RE	TP621	TP622	TP624
	GPS-04-16-055	14.00-15.99	16.0	4.00	2.00	5.50	★	★	
	GPS-05-18-060	14.00-15.99	18.0	5.00	2.50	6.00	★	★	
	GPS-06-20-075	16.00-18.00	20.0	6.00	3.00	7.50	★	★	
	GPS-06-20-085	18.01-21.00	20.0	6.00	3.00	8.50	★	★	
	GPS-06-20-100	21.01-28.00	20.0	6.00	3.00	10.0	★	★	
	GPS-06-20-120	25.01-28.00	20.0	6.00	3.00	12.0	★	★	
	GPS-07-20-120	30.00-39.00	20.0	7.00	3.50	12.0	★	★	

★主推牌号 Primary brand number ☆可选牌号 Optional brand ○按订单生产 Production to order

D 深孔钻 Deep hole drill

MIATI TOOLS

Milling Insert And
Turning Insert Tools

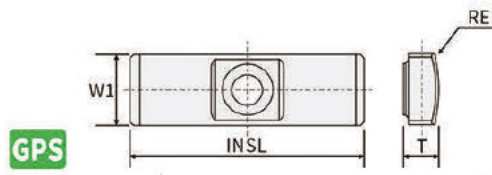

尺寸 Dimensions(mm)

可选牌号 GradeFor Choice

产品 Inserts Shape	型号 Type	直径范围 Diameter range	IN	W1	T	RE	可选牌号 GradeFor Choice		
							TPG21	TPG22	TPG24
	GPS-08-25-155	39.01-45.00	25.0	8.00	4.50	15.5	★	★	
	GPS-10-30-200	45.01-57.00	30.0	10.0	4.50	20.0	★	★	
	GPS-10-35-200	45.01-57.00	35.0	10.0	6.00	20.0	★	★	
	GPS-12-35-250	57.01-65.00	35.0	12.0	5.50	25.0	★	★	
	GPS-14-40-250	57.01-65.00	40.0	14.0	7.50	25.0	★	★	
	GPS-18-40-300	57.01-65.00	40.0	18.0	9.00	30.0	★	★	

★主推牌号 Primary brand number ☆可选牌号 Optional brand ○按订单生产 Production to order